



Vincotech's Compliant Pin

Advantages of Vincotech's Power Modules with Press-fit Technology

Revision history:	3
1 Abstract	4
2 Introduction	4
3 Vincotech's Press-fit Pin	5
4 Power Modules with Press-fit pins	6
4.1 Specification for PCBs	6
4.2 Components next to module pins	7
4.3 Current carrying capability	8
4.4 Mating the module and the printed circuit board	9
5 Press-in tool	10
5.1 Press-in process	11
6 Press-out tool	11
6.1 Press-out process	12
7 Conclusion	13

Disclaimer: The information in this document is given as an indication for the purpose of implementation only and shall not be regarded as any description or warranty of a certain functionality, condition or quality. The statements contained herein, including any recommendation, suggestion or methodology, are to be verified by the user before implementation, as operating conditions and environmental factors may vary. It shall be the sole responsibility of the recipient of this document to verify any function described herein in the given practical application. Vincotech GmbH hereby disclaims any and all warranties and liabilities of any kind (including without limitation warranties of non-infringement of intellectual property rights of any third party) with respect to any and all information given in this document.

Revision history:

Date	Revision Level	Description	Page number(s)
Apr. 2010	1	First release	11pages
Oct. 2010	2	Rework of document	12 pages
Jan. 2011	3	Corrected values in Table 1 - Specification of PTH	12 pages
Sept. 2011	4	PCB finishes	13 pages

1 Abstract

This application note describes the differences between a standard solder able pin and a Press-fit pin for Vincotech's power modules. Press-fit technology affects the reliability of the interconnection between PCB and pin, as well as the assembly process and the PCB requirements. Furthermore additional test procedures to the qualification tests are described. At the end of this application note press-in and press-out tools are presented.

2 Introduction

The Press-fit pin technology is a solder-less connection method, which ensures reliable mechanical and electrical contact. The first Press-fit solutions were established in the early 1970's. It was simply a pin with a rectangular, solid cross section. Driven into the round hole in the PCB, the four corners bit into the hole's plating, thus forming a gas tight bond. This technology was published in 1984 for the first time as the standard DIN 41611-5 and follow-ups in the *"IEC 60352-5 Solder-less connections – Part 5: Press-in connections – General requirements, test methods and practical guidance"*.

Nowadays modern Press-fit pins contain a compliant mechanism that allows plastic deformation when the pin enters the hole. This mechanism compresses as the pressing tool forces the contact into a PCB hole. This compliance compensates the whole size tolerance, helps to prevent damage the PCB, keeps spring force for long term and permits repairs. Press-fit pin insertion into the plated hole creates a highly reliable, well accepted, gas tight connection.

Within the industry segment, like the drive, solar and UPS market, a demand for improved reliability can be observed. Especially increasing numbers of components and therefore interconnections require better reliability. On the other hand cost improvement pressure of the market raises the need to reduce costs. The aim was therefore to develop an interconnection technology that would eliminate the need of soldering the power module whilst maintaining the reliability standards and electrical capabilities of the solder pin. This would make the assembly process of the modules easier, faster, and in the whole, more cost-effective. Furthermore the target was to establish the exact same layouts as those of the solder modules.

3 Vincotech's Press-fit Pin

Up to now, a number of different designs have been used to provide the resilient fit necessary for compliant pins. Over the years the design called “*eye of the needle*” has proved to be the one that provides the most reliable technology for optimizing both initial and long term retention forces. The spring-like design provides the proper balance between the required insertion force and the retention e.g. the force required to pull out the pin.

Figure 1 shows the shape of the Press-fit EON (Eye Of the Needle) pin, which is an improved Eye of the Needle head that Vincotech uses for its modules. The relatively harder middle part and the softer ends of the elastic part ensure constant force progression and high resilience. In addition, due to the elastic section, the head absorbs the deformation of the friction fit instead of deforming the plated through hole (PTH). This means that the module can be replaced and the same PCB re-used up to 3 times without any risk to the reliability or to the electrical properties of the system. The Press-fit pin however is not only based on brand new concepts; it combines the innovative Press-fit zone with every long-serving and proven features of the standard Vincotech solder pin, such as the pull-force relaxation mechanism (stress relief) for high mechanical robustness.

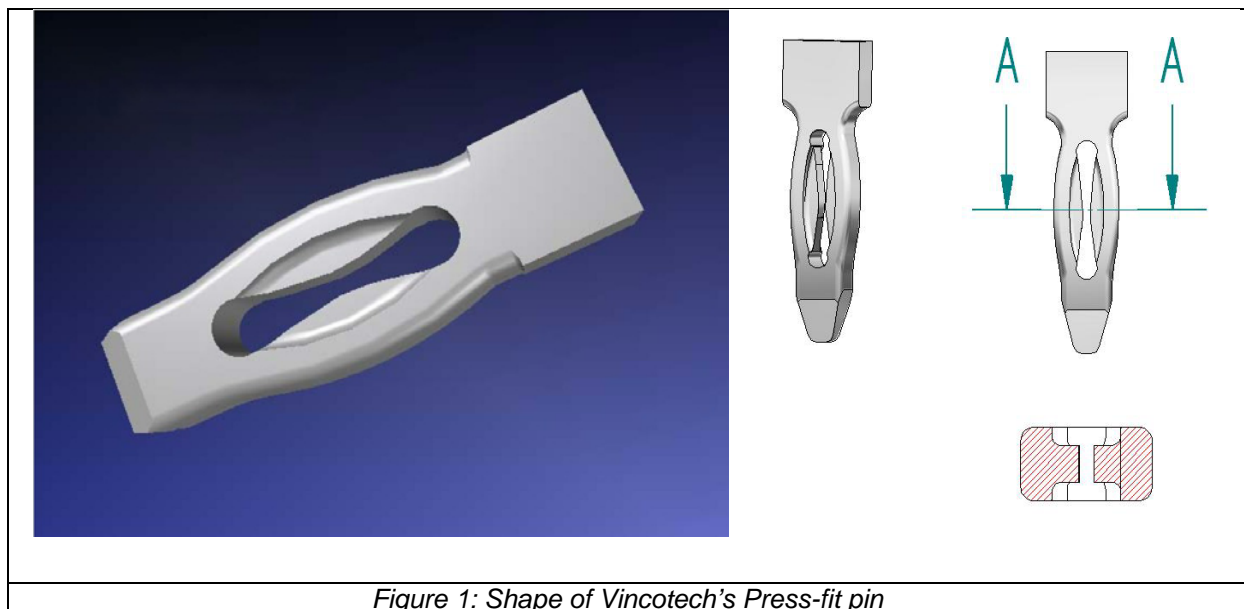

4 Power Modules with Press-fit pins

The Vincotech Press-fit pin was developed as a one-to-one replacement for the solder pin. This means that all Vincotech power modules, if standard or custom can easily be equipped with the Press-fit pin and do not require a PCB layout change by the customer. A further important feature is that the same press-fit area is used for all power ranges. The different versions of the pin vary only in length in order to accommodate the diverse housing heights.

4.1 Specification for PCBs

According to the IEC 60352-5 standard, there are some requirements referring to the Plated Through Hole of the PCB. On the one hand this ensures the proper functioning on the other hand Vincotech did all qualification tests with these values. The qualification tests are done on standard FR4 PCBs and on a surface finish of tin or gold. Printed board material meets the requirements of IEC 61249-2-7.

The tin finish fulfilled all the requirements. The gold finish showed lower press out forces that not complied with the mechanical requirements of the stress relief part.

The following table shows a specification of PTH:

	min.	typ.	max.
Recommended size of drill		1.6 mm	
Drilled hole diameter	1.575 mm	1.6 mm	1.625mm
Copper thickness in via	25 μ m		
Tin plating in via	1 μ m		
Final hole diameter	1.39 mm	1.45 mm	1.54 mm
Annual ring	100 μ m		
Thickness of PCB	1.6 mm		Not limited

Table 1: Specification of PTH

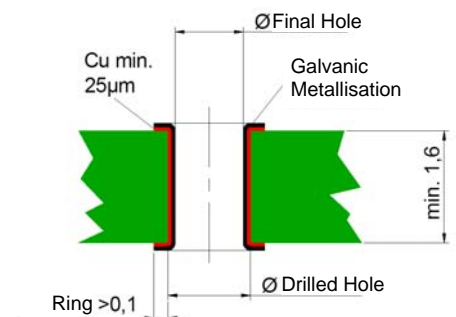

4.2 Components next to module pins

Attention should also be paid to other components like resistors, diodes or capacitors that need to be assembled next to the module. It is recommended to leave at least 4 mm between the edge of these components and the middle of the PTH. This ensures enough space for the pressing tool to back the PCB. Figure 2 illustrates a typical application.

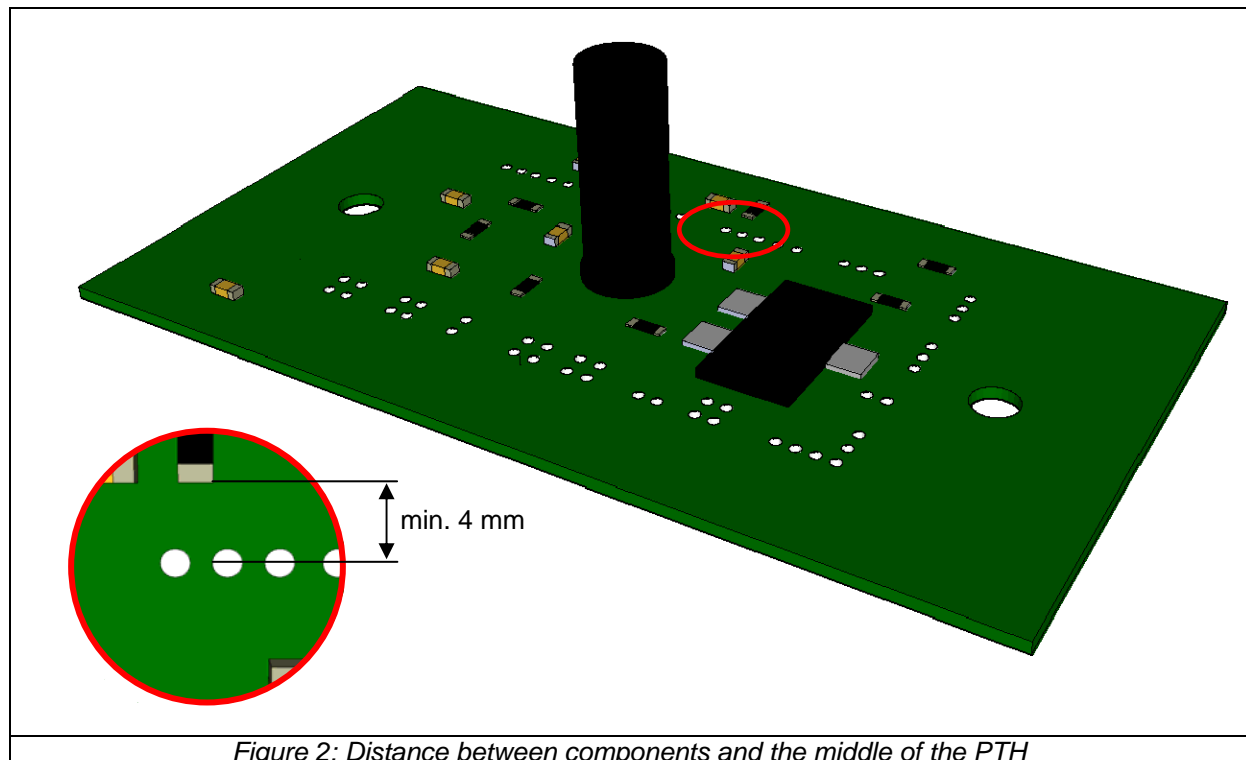

Figure 2: Distance between components and the middle of the PTH

The SMD ceramic capacitors as highly sensitive parts to mechanical stresses were additionally investigated. The test was carried out for Flow0 and for Flow1 module sizes. The Figure 3 shows the test boards, which were used to ensure that the mating and the retention of the module cause no damages to the ceramic capacitors. The parts with three different sizes (2220, 1812, 1210) are placed in various distances and directions to the rows of the pins. The capacitors were optically investigated after cross sectioning. In the case when the normal mating process was used, which will be discussed later, there were no damaged parts found. If the parameters were out of tolerance and the PCB could get excessive forces, cracks were formed in the ceramic body at the middle or at the edges of the metallization.

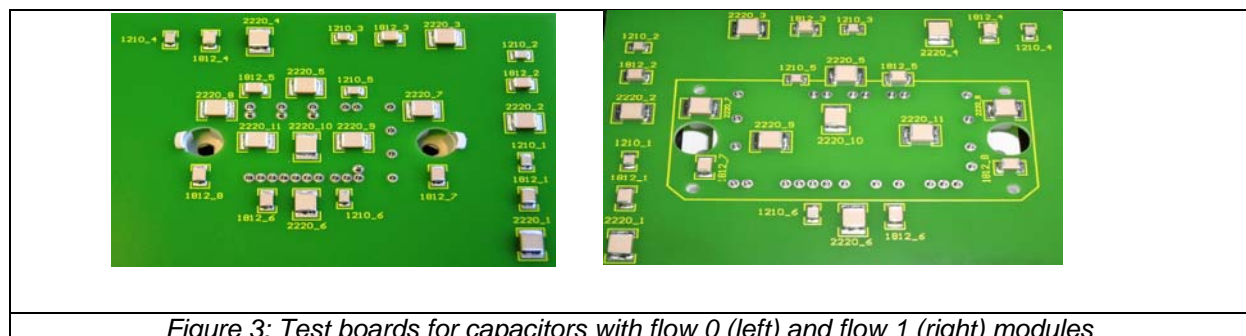
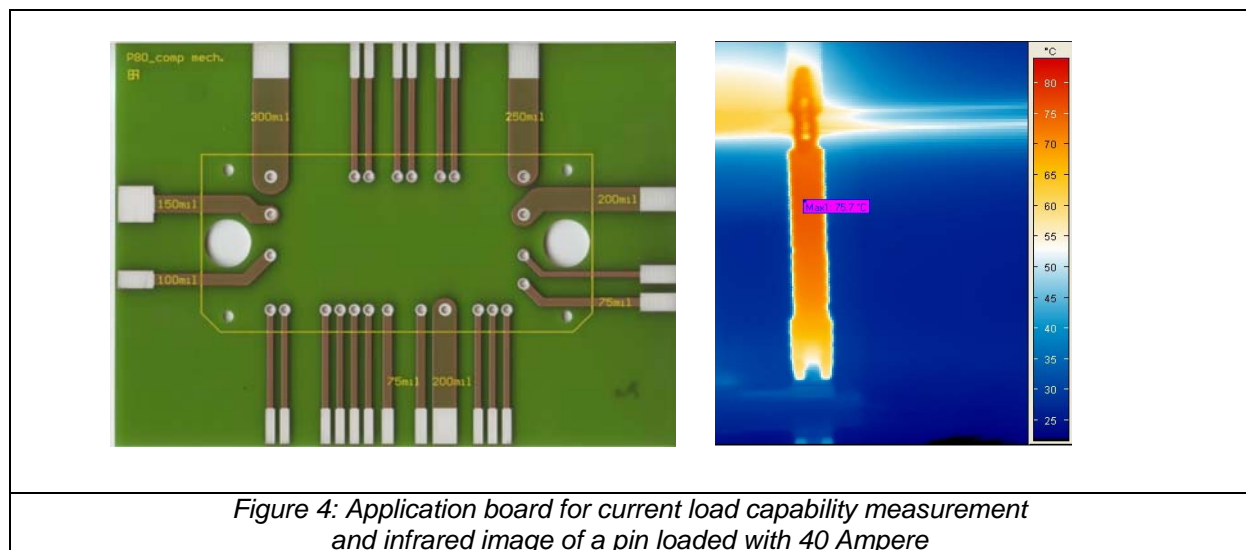

Figure 3: Test boards for capacitors with flow 0 (left) and flow 1 (right) modules

4.3 Current carrying capability

The current carrying capability of Press-fit pins was tested against standard soldered pins. As it was mentioned earlier one of the design targets was to create the possibility that the soldered and the Press-fit modules should be replaceable one to one. It requires that the current carrying capability of the new version is similar to the standard pin.

Different track widths were tested to get a good comparison. The Figure 4 illustrates the test board used for the measurements, and the temperature distribution of a pin. The PCB consists of 4 layers. The two outer layers have 105 μm copper and the two inner layers which are placed only around the holes have 35 μm copper thickness. The surface finish of the FR4 PCB is immersion tin. The copper thickness of the through holes is 25 μm . Figure 5 shows the current carrying capability of one pin inserted or soldered in a 250 mil wide track. The modules were mounted to a heat sink with thermal grease P12 from Wacker. The heat sink had a temperature of approx. 30 $^{\circ}\text{C}$.



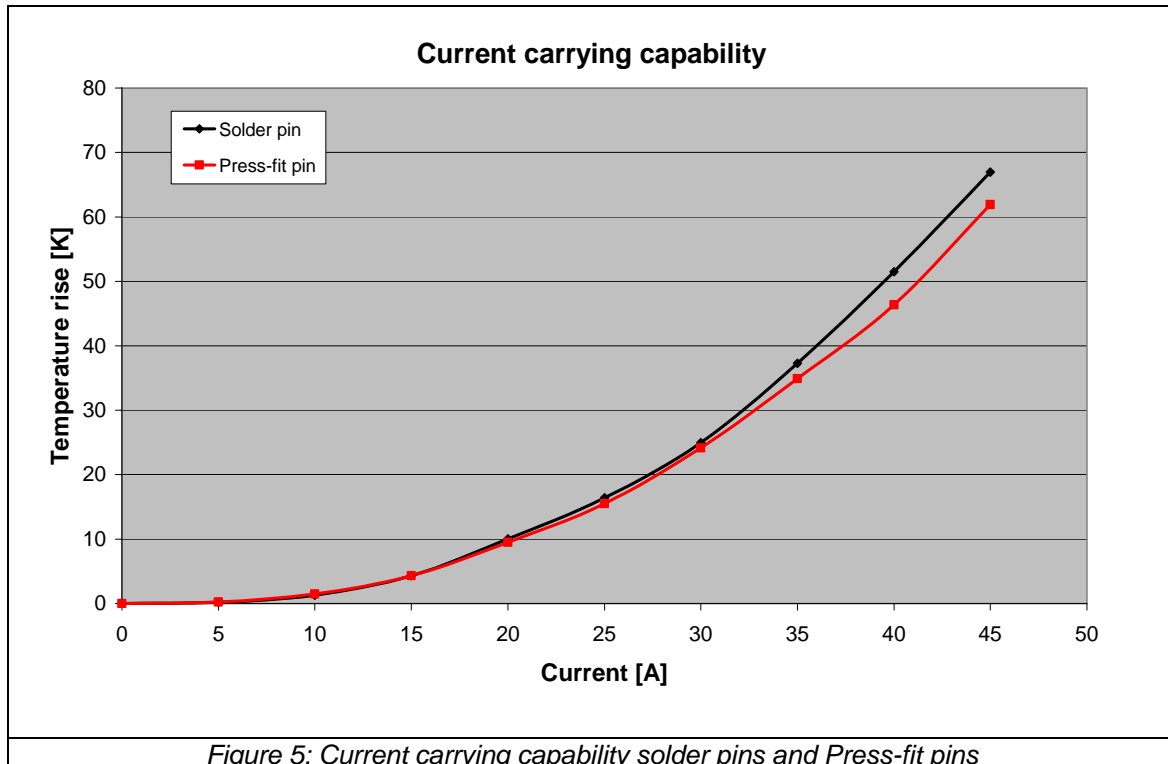

The measurement was done with the help of an infrared camera and the temperature of the hottest point was defined. See Figure 4. The results show a very similar temperature rise for both types of pins at a given current. Other parameters, like ambient temperature, the number and thickness of copper layers can influence the current carrying capability of the pins, thus in some cases it makes sense to test it for the specific application.

4.4 Mating the module and the printed circuit board

As its name implies the Press-fit module is mated in a printed circuit board by press-in. The presses which are suitable for this task can be categorized as manual, force assisted manual, semiautomatic and fully automatic. The manual, hydraulic- and pneumatic powered presses lack fine control of forces and distances. Using them for pressing Press-fit modules often requires additional visual inspection to ensure reliable quality. The PC controlled servo electric press eliminates those problems. They deliver a highly controlled mating of Press-fit modules. In these presses an electric servomotor drives a ball screw to provide the pressing force. Servo systems are designed for accurate control of speed and position and can react nearly instantaneously to sudden changes in force making them ideal to mate the Press-fit modules.

Servo electric presses can sense and record the parameters of the press in process, such as force and insertion path. The force and position can be correlated in order to control the proper seating of the modules, eliminating the need for 100% optical inspection. The recorded values ensure the traceability of the produced parts, and provide data for SPC card.

5 Press-in tool

The following picture shows an exploded assembly drawing of the suggested mating tools and a description of the different parts.

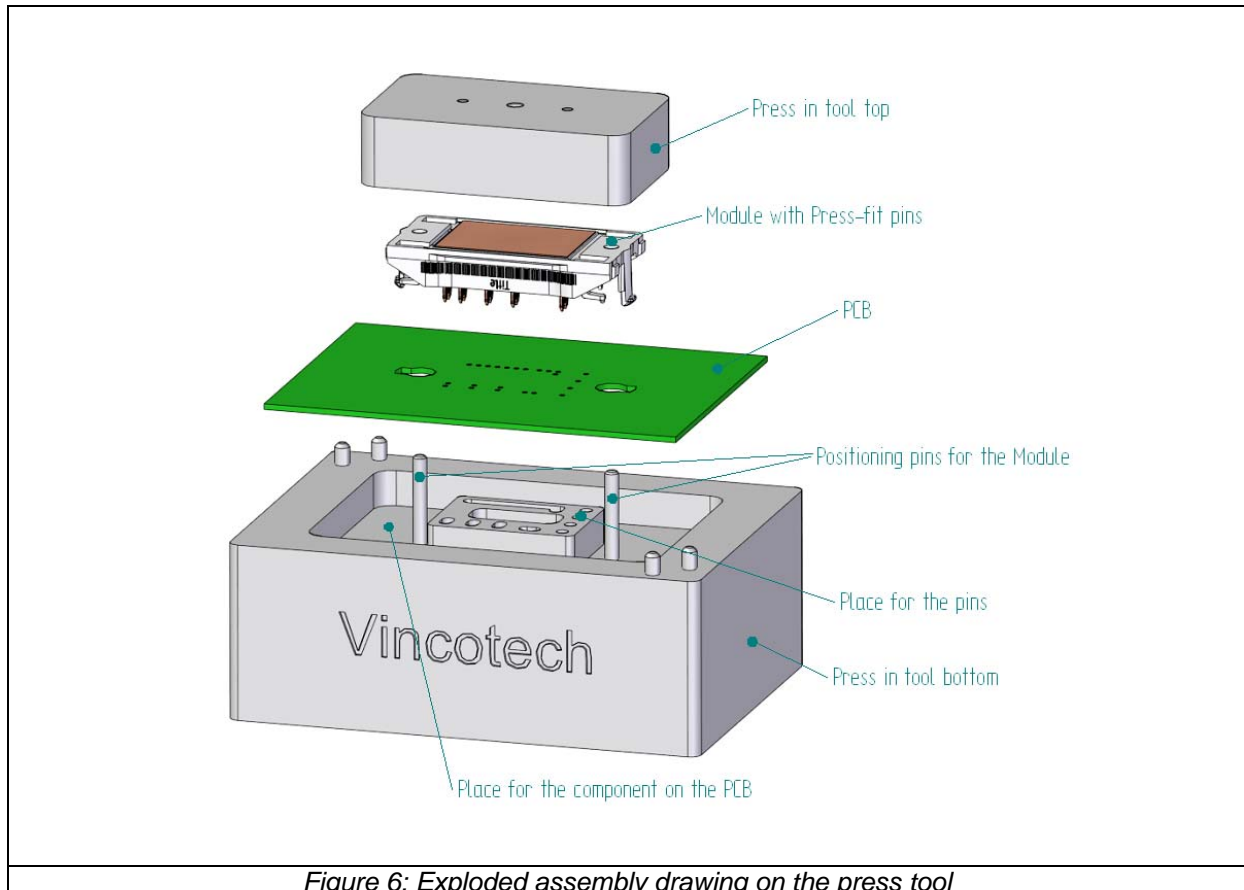

Figure 6: Exploded assembly drawing on the press tool

The lower part of the press-in tool is shaped on a way that it provides free space for the components mounted onto the printed circuit board. Size and position of the holes and cut-outs depend on the size and placement of the components on the board. The area around the holes supports the PCB. This area is important because it absorbs the force that is caused by the module pins during the press-in process. Mills and drills in this area leave space for the pins and have the same position as the pin pattern of the module. The recommended hole and cut-out dimensions for the Press-fit pins and the suggested material for tooling can be found in the specific handling instructions.

The lower part of the press-in tool should be fixed. The PCB will be positioned onto the press-in tool. After this the power module can be placed onto the PCB. The module is aligned with the positioning pins of the lower part.

The module is pressed with the upper tool, which has to be parallel to the lower part. Care should be taken to keep the bottom of the lower tool clean and free from any damages in order not to harm the surface of the module.

5.1 Press-in process

Figure 7 shows the press-in force versus press in path for a Press-fit module. A classic curve shows three typical phases. During the first phase the force is increasing nearly linearly, due to the resistance of the collapsing compliant section of the pin. In the second phase, the force is relatively stable, and - depending on the PCB's metallization- can be somewhat horizontal or decreasing slightly. At this point the compliant section has totally collapsed, and the force is simply that of overcoming friction as the pin slides through the hole. In the third phase, the force increases sharply, because the module body contacts the PCB's surface. It is not recommended to reach this third phase because it can cause unwanted stresses in PCB and module.

In case of Flow0 modules that are equipped with clips there is an additional segment visible on the curve. It can be found before the first phase of the classic curve. In this period the clips are bended and begin to slide through the openings of the PCB.

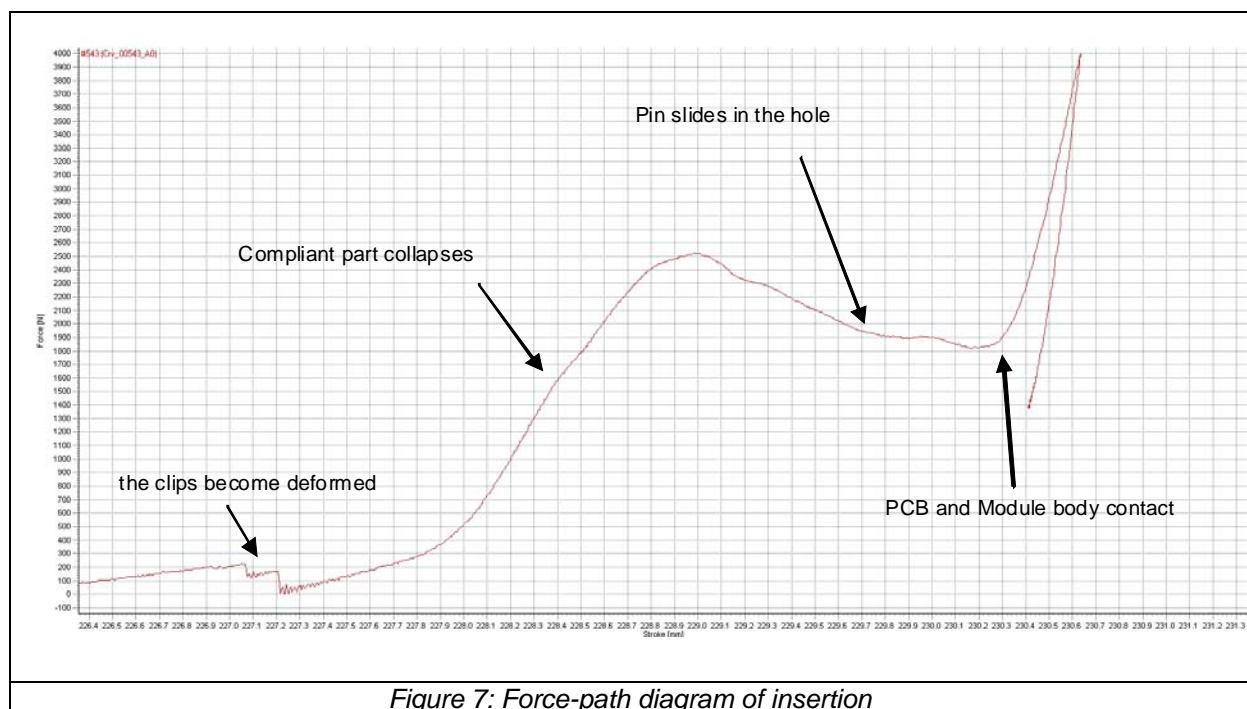

Figure 7: Force-path diagram of insertion

The exact process parameters and quality acceptance limits are given in the handling instructions of the Press-fit Modules.

6 Press-out tool

The specific tool to disassemble the modules from the PCBs has two parts similarly to the press-in tool. The lower part serves as a backing of the PCB. It is important that the backing is closest possible to the

side of the modules. In case the PCB bears parts in the line of the backing, it is possible to make a cut-out on the nest

The upper part consists of two pressure plates that are connected by springs. The pins on the lower plate serve to fix the PCB. With the aid of these parts the bending of the PCB while pressing can be prevented. There are two inwards bevelled tubes to aid the removal of the clips.

The ram fastened to the upper plate is designed according to the positions of the parts on the PCB and of the layout of the pins. In case of the use of thicker PCB (>2,5mm) it is not possible to press out the module with a flat plate due to the overhang of the pins. In that case pressing positioned according to the pin layout is necessary.

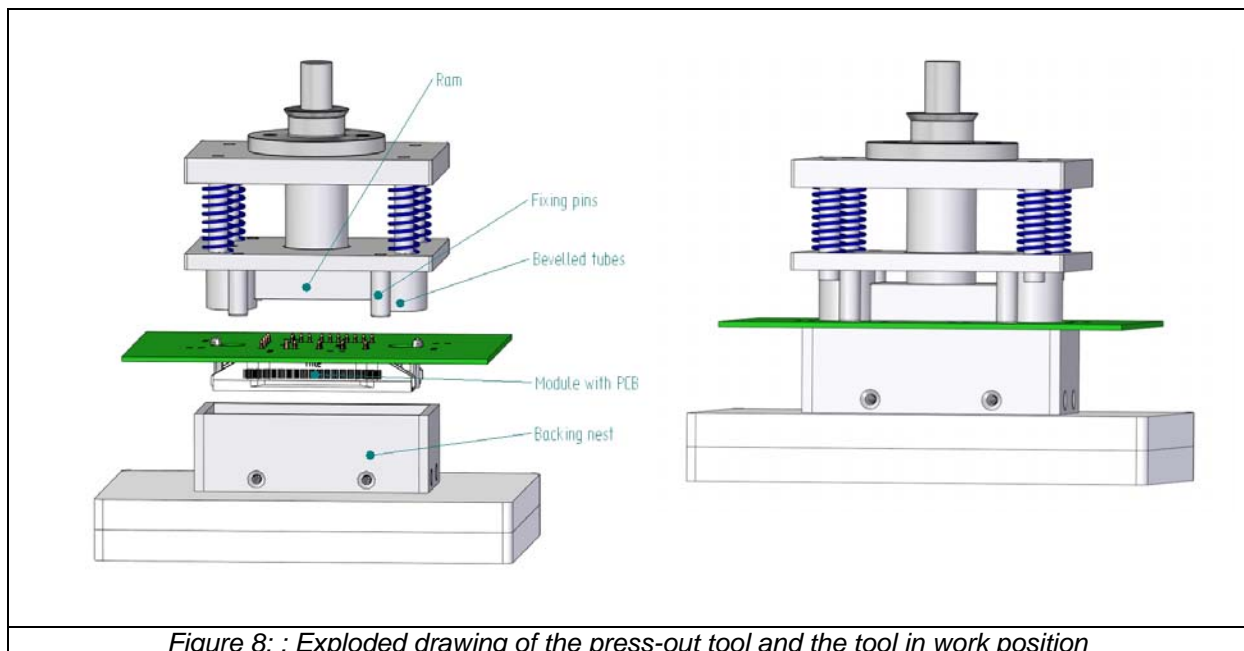

Figure 8: : Exploded drawing of the press-out tool and the tool in work position

Drawings will be provided on request. Please contact your regional sales manager or fill in the contact form on Vincotech's webpage.

6.1 Press-out process

After inserting the modules into the nest, the downwards moving press fixes the PCB with the lower plate through the springs. The pins are pressed through by the onwards moving pressing ram.

The Figure 8 shows a typical force-distance curve of the pressing-out. It is typical for this curve, that a characteristic peak appears that indicates the breaking of the cold welded connection.

The exact parameters of the press-out process are given in the handling instruction of the Press-fit modules.

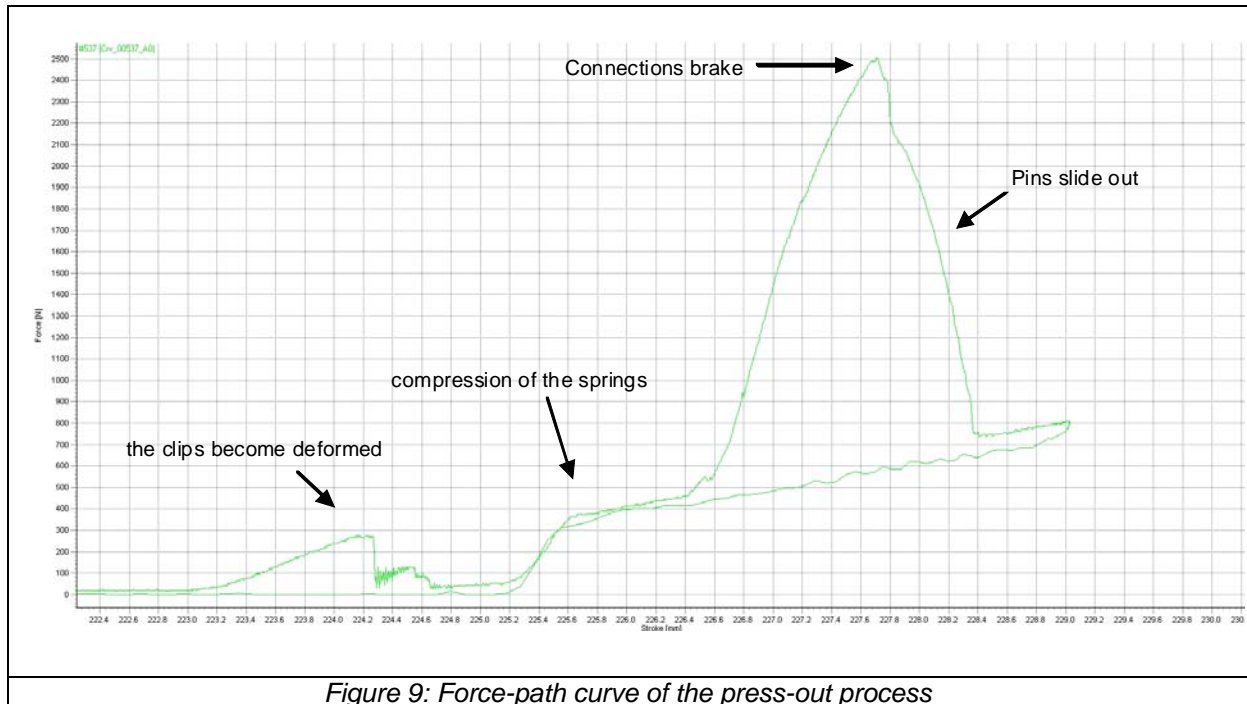

Figure 9: Force-path curve of the press-out process

Note:

After removing the module the PCB can be used again for two additional times.

If a disassembled module should be used again it is recommended to solder the module to the PCB because of a remaining deformation of the pins.

7 Conclusion

The Vincotech's Press-fit pin offers the perfect solution for solder-less assembly. Today, as cost saving very often leads to compromises in quality, Vincotech's new Press-fit technology goes against the trend: highly reliable and electrically equal to the solder pin, this new interconnect technology reduces assembly time and cost whilst increasing reliability. Added benefits are design flexibility, free choice of PCB thickness, and easy PCB repair and re-use.