

2nd Generation of PFC Solutions

Temesi Ernő, Michael Frisch, Tyco Electronics / Power Systems, Sept. 04

To achieve higher efficiency is one of the highest priorities in all power electronic applications. With the new standards active power factor correction is a must in many applications. The additional power dissipation for the electronic components might increase the size of the heat sink and the whole application. The target is to reduce the losses to a minimum without an increase of the costs

Introduction

The standard EN61000-3-2 is mandatory for power applications connected with the public power grid. For many applications the additional function of an active PFC have to be integrated additional to the existing functions. The size of such applications is often defined by the heat sink which have to dissipate the power losses. To keep the heat sink as small as possible by integration of the additional function of PFC is a important target. Power losses are generated in the semiconductors and in the choke. To optimize the circuit with the right selection of components in respect of lower losses is a must. With the new idea of a high efficiency PFC the losses of 2 of the 4 input rectifiers are eliminated at all, the losses of 1 semiconductor junction per half-wave is eliminated.

Standard PFC-Boost-Topology

In most cases the boost topology is used for active power factor correction. The current have to pass here at least 3 semiconductor junction layer additional to the output load per half-wave.

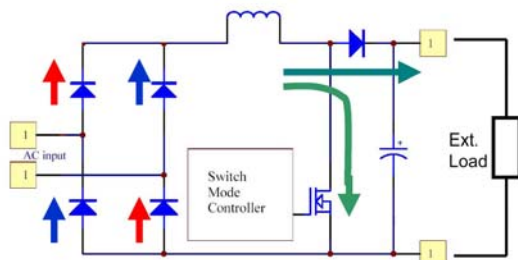

The input rectifier convert the AC voltage into a pulsed DC-voltage. The PFC-circuit boost both half waves to the DC-output voltage.

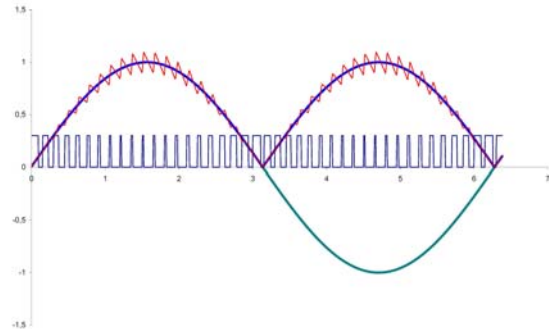

Function of High Efficiency PFC

The PFC choke is split into 2 inductors with half of the inductance. Eliminating the input rectifier for each half-wave a boost stage is now necessary. But the current have to pass a total of only 2 semiconductor per half-wave.

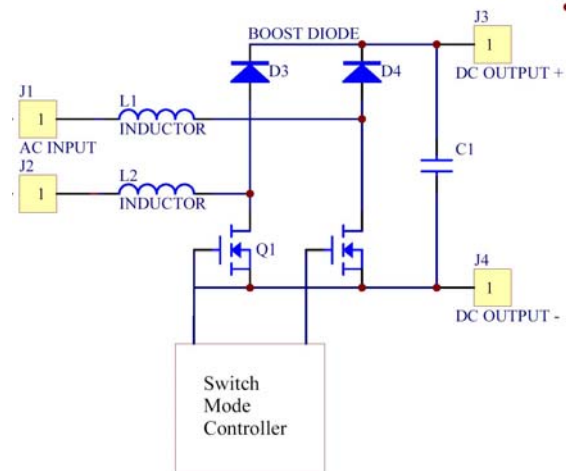

Simulation Results

In theory this new topology seem to be a efficient alternative to reduce losses in active PFC applications. But the next step is to check theory with simulation.

The following circuit is used for the simulation:

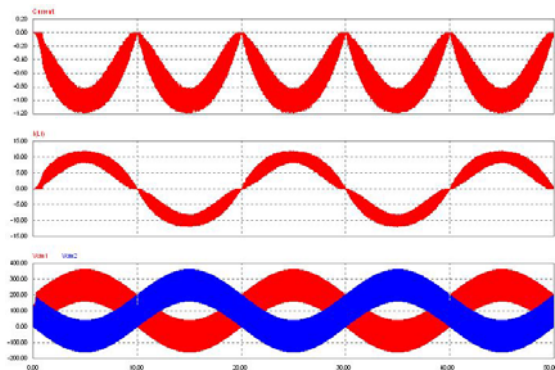
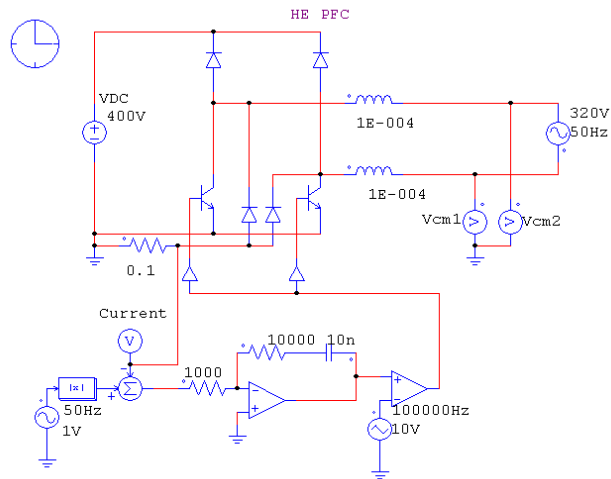

The results are deflating:
All output signals of the PFC circuit are oscillating with the PWM frequency relative to the input.

The problem is systematic, the reason is the connection of both input lines to an PFC-choke. The outcome of this is the floating of the output with high frequency relative to input source. Due to that is not possible to solve the EMI problem with external filtering.

The DC-output and the circuit connected oscillate with high frequency relative to the public power grid. The consequential high EMC emission is not acceptable for most applications. The design of applications with isolated transformer will be very difficult with this topology. Applications without transformer as motor drive are completely impossible.

New Topologies

Due to this disappointing result, new possibilities were evaluated to get a high efficiency PFC solution without the disadvantage of EMC emission.

Dual Boost Topology

A new topology invented by Tyco Electronics does solve the problem. Different to the 1st

idea the choke is not split, here 2 chokes with the same inductance as in the standard boost topology are required. But only 1 inductor is used per half wave. The other one is bypassed by additional rectifiers.

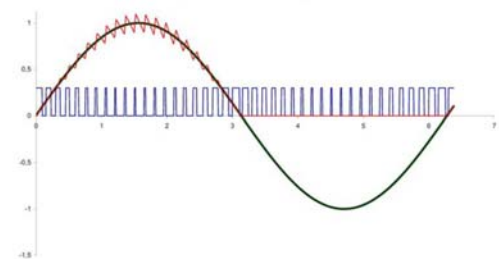
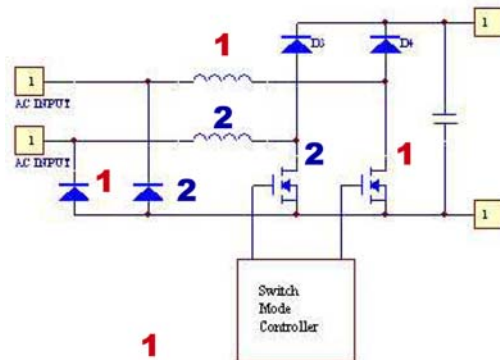

With this solution the output does not oscillate with high frequency relative to the AC-input or GND. The behavior is identical to the standard boost topology. But the losses of the input rectifiers used in the standard boost topology are cut into halves.

1. The 1st half wave is boosted with one PFC-circuit to DC-output voltage. The 2nd choke is bypassed by the 1st rectifier.
2. During the 2nd half wave the 2nd PFC-circuit boost the input to DC-output voltage. Here the 1st choke is bypassed.

Bi-directional Boost Topology

With a 2nd topology it is possible to get the benefit of the high efficiency PFC with only 1 choke:

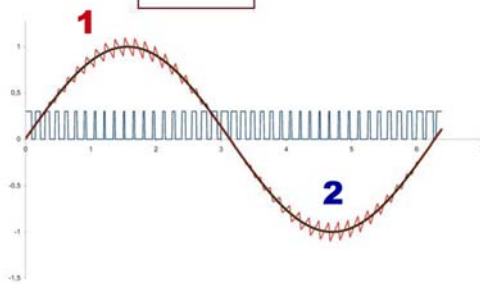
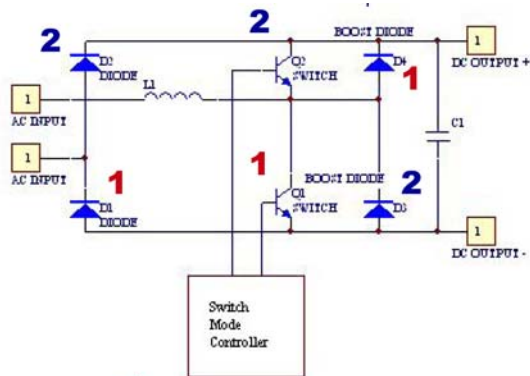

Here the current flow in the PFC-choke is bi-directional.

1. The positive half wave is boosted with the low side switch and the high side boost diode. The low side rectifier builds the return path.
2. The negative half wave is boosted with the high side switch and the low side boost diode. The high side rectifier builds the return path.

Also with this topology the losses of the input rectifiers used in the standard boost topology are cut into halves. This circuit has the advantage of using the identical PFC-choke as in the standard boost topology.

Efficiency Advantage with HE-Topology

In a system with 230V_{AC} input voltage the rectifier losses of the new HE-PFC are ca. 0.5% of the total input power (at $V_{out} = 400V_{DC}$, $P_{out} = 6kW$). In a 110V_{AC} system, the rectifier losses of the new HE-PFC are ca. 1% (at $V_{out} = 400V_{DC}$, $P_{out} = 3kW$).

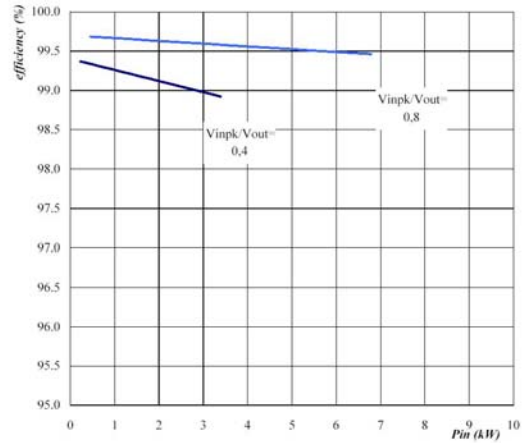

Conditions: $T_{jmax} = 125\text{ }^{\circ}\text{C}$

The efficiency of the semiconductors in the 230V system are: 97.4% (at $V_{out} = 400V_{DC}$, $P_{out} = 6kW$, $f_{PWM} = 80kHz$). The efficiency advantage is ca. 0.5%.

total semiconductor efficiency = f(Pin)

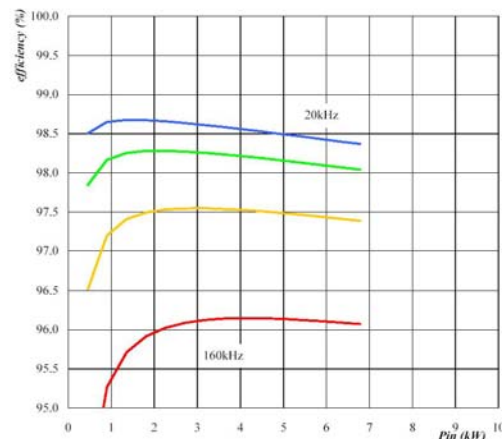

Conditions: $T_j = T_{jmax}$
 DC link = 400 V
 $V_{inpk}/V_{out} = 0.80$
 Switching freq. parameter: fsw from 20 kHz to 160 kHz * 2 steps

The efficiency of the semiconductors in a 110V_{AC} system are: 94.8% (at $V_{out} = 400V_{DC}$, $P_{out} = 3kW$, $f_{PWM} = 80kHz$). The efficiency advantage is ca. 1%.

total semiconductor efficiency= η (Pin)

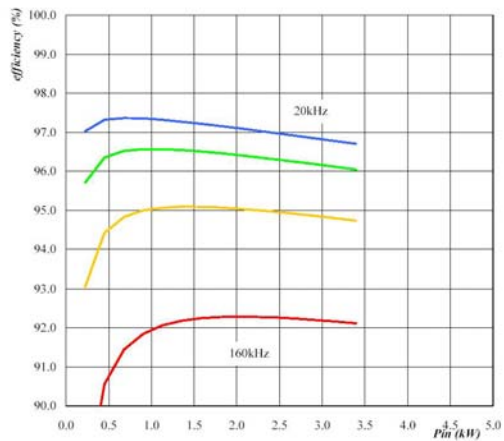

Conditions: $T_j = T_{jmax}$
 DC link = 400 V
 $V_{inpk}/V_{out} = 0.4$
 Switching freq. parameter: fsw from 20 kHz to 160 kHz in * 2 steps

In both cases 110V_{AC} and 230V_{AC} input, the semiconductor losses are about 19% reduced compared with the standard boost topology.

Module Solutions

Tyco Electronics offer modules supporting both topologies.

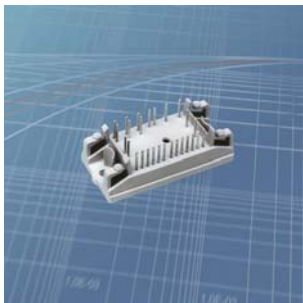

flowPFC 0 – HE

The Tyco Electronics module **flowPFC 0 – HE** supports the new dual boost topology:

Features:

- up to 4,5kW at 100kHz
- all power semiconductors for dual boost stage integrated
- integrated capacitor for low inductive output
- shunt resistor for current sensing
- temperature sensor

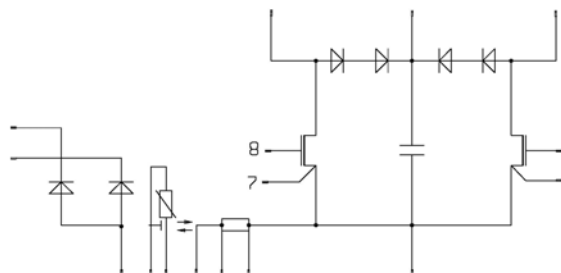

fastPACK 0 – PFC

The Tyco **fastPACK 0 – PFC** module in H-Bridge configuration supports the new high efficient bi-directional boost topology.

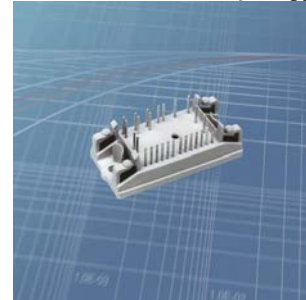

Features:

- up to 6kW
- all power semiconductors for bi-directional boost stage are integrated.
- the pinning supports the low inductive connection of external snubber capacitors at the DC-output
- temperature sensor

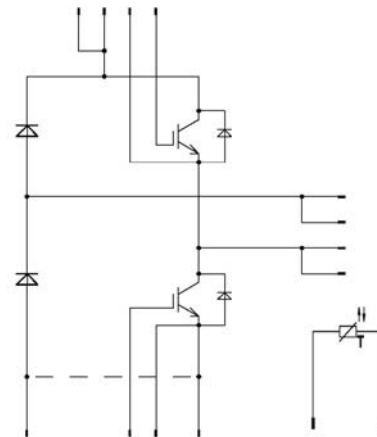

Summary

The new topologies are able to achieve a loss reduction in the semiconductors of ca. 19%. Tyco Electronics Power & Switches offer products for the 2 high efficiency topologies for active PFC.