

Motor Integrated IPM-Solution for Servo Drive Applications

Michael Frisch Jan. 2006, TYCO Electronics / Power Systems

Distributed drive technology is becoming a key word in the inverter industry. For this approach the inverter has to be integrated into the servo motor. But servo applications with motor-integrated power components have advanced specifications regarding mechanical, thermal and functional features of power modules. The additional requirements and possible solutions are discussed and a complete IPM solution covering these requests is introduced below.

Abstract

Motor integrated applications have additional requirements regarding the power components compared with applications used in switching cabinets [1]. Additionally, servo applications require an advanced thermal and electrical performance to cover the high dynamic operation of the application. Following are some of the conditions which generate additional requirements for a 1200V / 25A IPM designed for motor integrated servo application:

Mechanical Conditions:

- hermetic IP65 housing can cause humidity and condensation water on electrical circuits at low temperature
- electronic circuit is exposed to vibration and mechanical shock
- available area is limited and restricts the freedom of the mechanical design

Thermal Conditions:

- up to 90 °C heat sink temperature
- short peak power dissipation due to dynamic operation
- no air flow

The above conditions require the following additional features from the power circuit:

- high efficient electrical components for reduced power dissipation
- improved load cycling capability
- heat storage for sophisticated dynamic operation
- excellent thermal contact for all power dissipating components (IGBT, FRED, Shunts, etc.)
- thermal coherent system for the logic components (e.g. opto driver etc.)
- humidity protection for the high voltage area
- rugged mechanical construction
- compact outline

This list of requirements creates an extension of the specification for an intelligent power module solution with the goal to cover the additional requirements in the most efficient way. The final IPM solution is presented and reviewed according to the original specifications.

Requirements for Motor Integrated Servo Applications

Servo applications have different requirements compared with standard drive solutions.

Dynamic Operation

The extremely dynamic nature of servo drive applications leads to high load cycle capability

requirements for the power electronic. Whereas, for slow moving applications such as fans, air-conditioner, etc. only the thermal resistance R_{TH} is important for the thermal load cycle stress of the semiconductor.

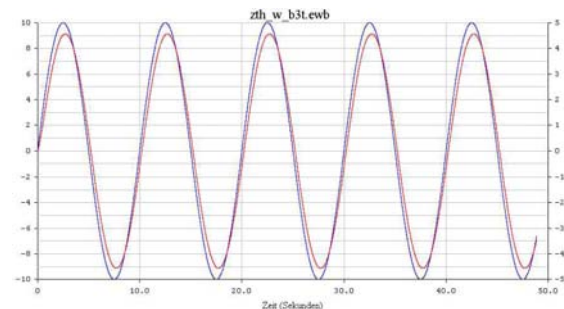

Figure 1.: Comparison of the dynamic behavior of a power module with 3mm base plate (red) and a direct pressed solution (blue) at 0.1Hz load cycle

In dynamic servo applications the peak current is often 4 times higher than the nominal current and normally the heat sink is only designed for the average power dissipation. The higher the dynamic requirement of the application is the more important becomes the thermal capacity. This leads to even more influence of the size of the base plate on the amplitude of the chip temperature.

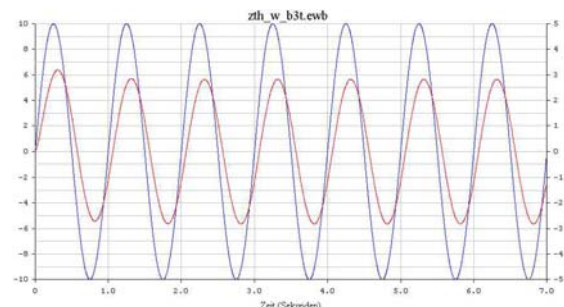

Figure 2.: Comparison of the dynamic behavior of a power module with 3 mm base plate (red) and a direct pressed solution (blue) at 1Hz load cycle

Acceleration and deceleration with high regenerative energy cause higher loads for the anti-parallel freewheeling diodes in the inverter. Therefore, the rating of the diodes has to be bigger than in standard drive applications. For example, for load cycles at a frequency of 100Hz only the die, the substrate metallization and the substrate itself are participating on the heat

storing and influence the amplitude of the chip temperature. The base plate has almost no effect at this relative high load cycle frequency.

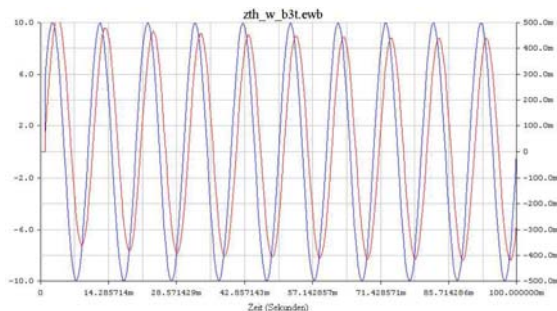

Figure 3.: Comparison of the dynamic behavior of a power module with a 3 mm base plate (red) and a direct pressed solution (blue) at 100Hz load cycle

Current and Voltage Sensing

For the accurate control of high end servo drive applications it is necessary to measure the exact output current and the DC bus voltage. The current signal is required for the vector control of the PWM generation and the DC bus voltage detection allows the compensation of any variation in the DC bus.

Motor Integration – What’s the Difference?

For the power electronic the integration into the motor introduces following additional requirements:

- compact outline
- high vibration and shock capability
- ruggedness against condensation caused by hermetic housing

Thermal Conditions

Motor integration normally means that the electronic will be hermetically packaged. Furthermore, the motor is an additional heat generation source. This environment provides some restrictions for the design of the electronic circuit. In comparison the standard housing used for switching cabinets are open and the circulating air provides cooling for the components placed on the PCB. In this case, only the high power components like the inverter IGBTs and diodes have to be placed on a heat sink. Components with low power dissipation like shunt resistors, gate drivers, logic power supplies and so on, can be placed on the PCB. In a motor integrated design with its hermetic

sealed housing this is not possible! Due to the small temperature gradient inside the housing, the housing surface temperature of the power module will be close to the one of the chip, and all power dissipating components have to be placed on the heat sink. When temperature sensitive components (e.g. optocoupler) are used, the PCB has to be cooled or thermally decoupled from the power electronics as well.

Intelligent Power Module Solution

Integrated Functions

Most Intelligent Power Module (IPM) solutions on the market integrate only parts of the gate drive circuit. This results in a non-optimized power module that increases implementation cost, as interaction with this interface will be complex:

- The gate driver is integrated but the user has to deal with high voltage components for the high side power supply. The required distances on the user PCB are problematic to implement in compact system designs
- Power semiconductors are integrated but shunt resistors are not. The user has to take the additional effort to develop a thermal solution for this external power dissipating components
- The switching behavior is not adjustable but parasitic inductions, such as inductivity of the DC-circuit, which have to be compensated, are dependent on the user design.

For a coherent IPM solution complete functional blocks should be integrated into one component:

- complete 3~ inverter with power semiconductor, DC-capacitor and temperature sensor
- gate driver circuit with high side power supply
- current sense circuit, including shunt resistors

The logic signals should be on the voltage level of the microcontroller. This is usually DC- or a save isolated potential. In servo drive applications several sensor signals are connected to the microcontroller. These signals are normally at save potential the microcontroller has to be safely isolated as well. To be compatible with this approach all sensor and control signals of the IPM have to be safely isolated.

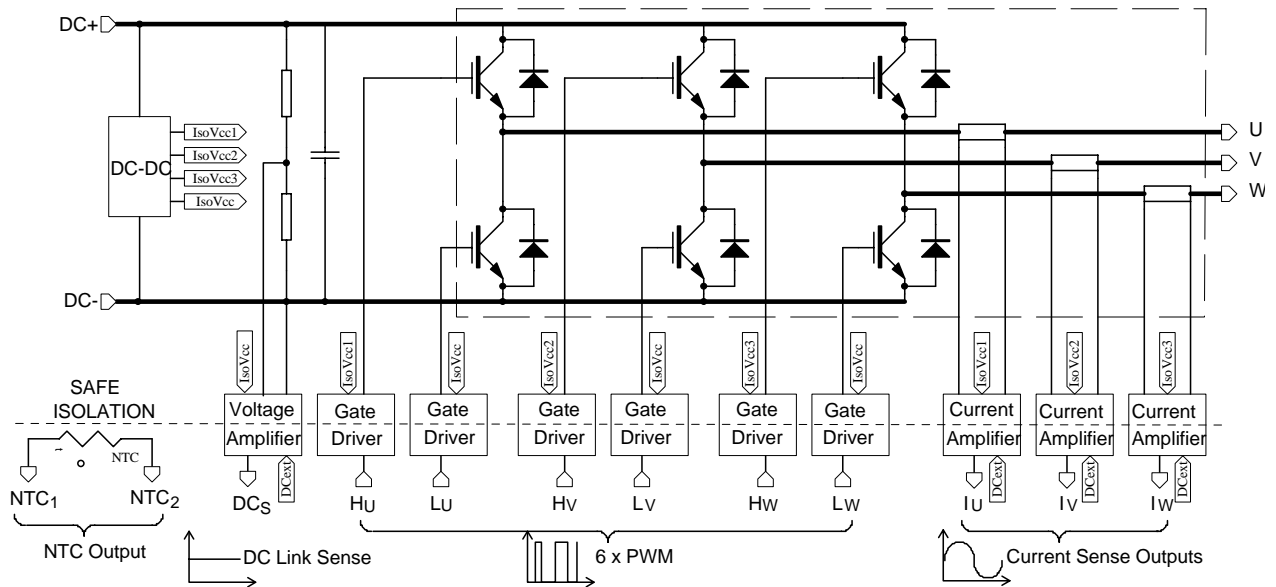

Function Block of the motor integrated IPM solution

In an IPM including these functions only the DC-link and the motor output lines remain as high voltage connection to the outside circuit. All the logic and sensor signals are isolated and can be connected without any additional effort. The power supply for the IPM logic and drive circuit can be generated on board from the DC-bus.

Module Integration

To integrate all these functions in one power module the additional requirements of servo drive and motor integration have to be incorporated:

- Pulsed power dissipation of the motor and the electronics caused by the dynamic and cyclical operation of servo applications
- No air cooling of the driver circuit and the logic components on the PCB.
- Condensation on the components at low temperatures
- High vibration and shock resistance

Thermal Management

The maximum average output power of a servo motor is only 1/4th of the maximum peak power. To utilize the capability of the motor also the power electronics must be designed in order to provide a continuous output power of 100% and for one second 400%. The heat plate must be designed for the 100% output power but thermal capacity has to be provided by the design to store the energy during the 1s at 400%. This operation with intervals of high and low power dissipation generates load cycle impact onto the power component. The lifetime of power semiconductors is heavily dependent on the number and amplitude of power cycles the components are exposed. Wire bond and chip soldering are usually the limitation. Referring to these elevated conditions the power module design has to take effort to reduce the stress at the critical sections.

DBC as Power Substrate:

The typical failure mode in power applications is the difference in thermal expansion of the materials used. The heat sink or motor section used as thermal contact for the power electronics is usually made of aluminum with the highest thermal extension coefficient of the system with $23.5 \cdot 10^{-6} 1/K$. The power emitting silicon chip has a thermal extension coefficient of only $2.5 \cdot 10^{-6} 1/K$ and the materials used between the chip and the heat sink have to compensate this thermal mismatch. The 1st junction is the solder connection between chip and substrate. To reduce the stress of this solder connection DBC ceramic material is used for the power substrate. The ceramic material is 0.385 mm Al_2O_3 with 0.3 mm Cu layer on both surfaces. The thermal extension coefficient of the ceramic is with approx. $9 \cdot 10^{-6} 1/K$ between Cu ($17.7 \cdot 10^{-6} 1/K$) and the coefficient of the silicon die. This arrangement avoids excessive mismatch between the used components. The top surface Cu-layer is structured with tracks for the power layout. The Cu-structure with a track thickness of 0.3 mm increases the thermal capacity and reduces the peak temperature of the chip for peak load with durations of up to 10ms.

The electrical isolation but thermally conductive interface is built by the ceramic.

For an optimum thermal connection the DBC is soldered to a Cu base plate.

Cu Base Plate:

Here a 4mm Cu-base plate is allocated to store the pulse energy. Below the IPM solution with base plate was compared with a module using direct pressed DBC technology.

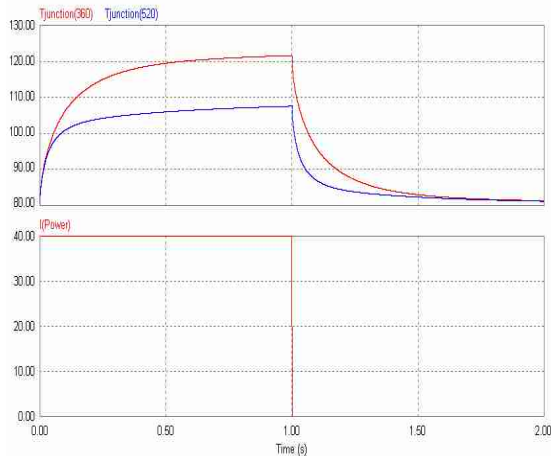

Figure 4.: Comparison of 2 modules with identical chipsets without base plate (red Tj360) and the IPM (blue Tj520) with 4 mm base plate.

In this comparison one IGBT is emitting 40W for 1s. After this time, the IGBT without base plate reaches a temperature of ca. 122°C. The IGBT in the IPM reaches only 108°C. This will increase the life time according to “Coffin Manson” [3] by about 5 to 6 times.

As the base plate area is much bigger than the power substrate this base plate will also work as heat spreader to reduce the thermal resistance in the thermal interface between power module and heat sink.

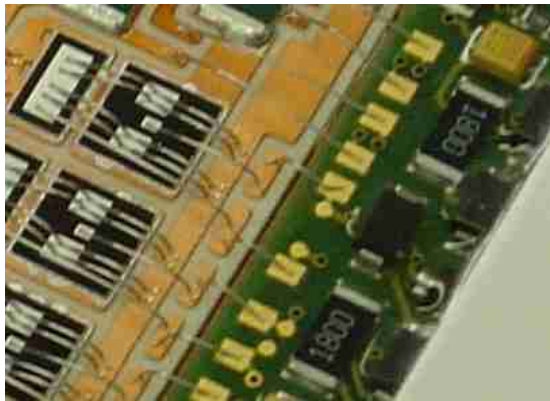

Figure 5.: Interconnection between semiconductors on a DBC power substrate and logic components on a PCB.

Integrated PCB:

Servo drives are used in harsh environments therefore the electronic will be protected by an IP65 compliant housing. But this will lead to the following challenges:

- At low temperature water will condense on the surface of the PCB and the assembled components.
- In the motor integrated solution only limited space for the power electronics is available.
- The system PCB is not cooled by forced air or air convection.

The condensed water problem and the overall size target can be solved with module

technology. All components are protected with a high isolation (ca. 10kV/mm) potting material. This potting helps to reduce the isolation distance between tracks and components inside the module and avoids the problems of reduced voltage isolation capability when water condenses on the circuit surface. In an open housing as it is used in the switching cabinet air flow, power supply, gate driver and shunts are possible on the PCB. But in a hermetic housing for all components with power dissipation a coherent thermal solution has to be found. In the new IPM the PCB is attached with an adhesive and thermal conductive interface to the base plate. This reduces the PCB temperature to base plate temperature and allows the usage of optical components such as optocoupler, gate driver and isolation amplifier. This approach makes it also possible to integrate the power supply for the gate driver and the logic components on to the PCB. The expensive DBC substrate is used only for the high power components.

Vibration and Shock

Power electronics in motor integrated applications have to withstand the same conditions as the servo motor itself. The demand for increased vibration and shock resistance bares a special challenge for the electronics. The selected system uses SMD components on PCB, bare dies on DBC substrate and the interconnection between the substrate and the PCB is realized with bond wires.

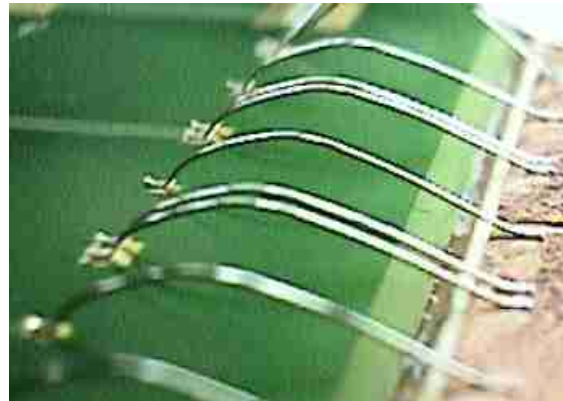

Figure 6.: Wire bond connection between PCB and DBC

Inside the module there are only the Cu-tracks on the PCB as well as DBC substrate, and the wire bonds used as interconnection.

The small weight makes this technology is very rugged against vibration and shock.

The technology is tested up to 80g shock without showing any problems. The limiting factor are the big SMD components which have to be mechanically connected e.g. with the module cover to avoid any mechanical amplitude when shock and vibration are applied.

Structural Design Concept of the IPM

The result of these extended specifications is the following module concept:

- DBC power substrate containing the power semiconductors and the shunt resistors for current sensing.
- PCB including fast DC-link capacitors, gate driver, current sense logic, DC-link voltage detection, temperature sensor, logic power supply and the safe isolation of all output signals
- Convex shaped 4 mm Cu Base plate with a soldered DBC and a thermally conductive glued PCB
- Plastic package filled with high isolating potting material

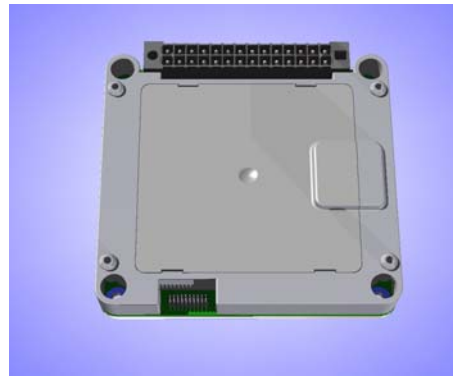

Figure 8.: The serial product **flyerIPM**, V23990-P520-F

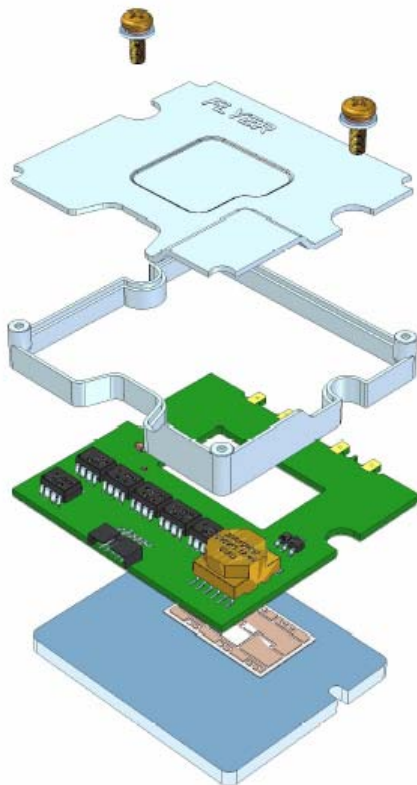

Figure 7.: Structural design of a IPM for integration into servo motors

Standard Product Example

The intelligent power module **flyerIPM** integrates the following features:

- 1200V/25A 3~ IGBT inverter
- fast DC-link capacitor (720nF)
- gate driver
- 3 PHASE current sensing
- DC-voltage sensing
- temperature sensor
- integrated logic power supply
- safe isolation of all logic signals
- rugged package
- 4 mm base plate

Conclusion

Motor integrated servo applications have special requirements regarding the used power electronics. A power module is the optimal platform to cover this extended specification. The features above are the tools to solve the extended requirements of motor integrated servo applications:

- complete integration of electrical function blocks
- compact design
- coherent thermal management
- rugged package

References

- [1] The New Built-In Servo drive "Posmo Si" – an alternative approach to Mechatronics (CIPS June 2000)
Dipl.-Ing. (univ.) Sebastian Raith, Siemens AG Erlangen, Germany
- [2] Advanced integration for mechatronic drive systems (PCIM-Europe 2001)
Sebastian Raith, Torsten Franke
Siemens Automation & Drives, Erlangen, Germany
- [3] *Qual. Reliab. Engng. Int.* 2002; **18**: 81–98 (DOI: 10.1002/qre.468)
W. H. GERLING¹, A. PREUSSGER¹ AND F. W. WULFERT²
¹Infiniteon Technologies, Munich, Germany
²Motorola, Munich, Germany