

Active PFC with Inrush Limitation and Short Circuit Protection

Temesi Ernő, Michael Frisch, Tyco Electronics / Power Systems, Sept. 04

Output current rates of > 500 W require a specific input control, which limits the higher start-up current generated by the loading procedure of the DC-link capacitor after activation of the PFC. The switching system above, for which a patent has already been filed, will not only solve this problem - moreover it also provides a short-circuit protection at the output.

Input Start Switch as Short-Circuit Protection and Protection against High Switch-On Currents

Description of functions:

1. After application of AC voltage at the input, the SCR's of the semi-controlled input rectifier are not activated. The output capacitor is loaded via a current limiter and auxiliary rectifier. As soon as the controller begins to contact the PFC transistor, the PFC coil will be loaded with current. When switching-off the transistor, the output voltage of the PFC coil will be limited to the initial output voltage level at the PFC capacitor via the PFC diode.
2. When the voltage is high enough, the voltage reduced by the winding ratio $N1/N2$ via the auxiliary winding at the PFC coils activates the semi-controlled rectifier, in order to limit the losses at the current limiter.
3. In case of a short-circuit at the PFC output, the PFC diode clamps the voltage at the PFC coil down to zero and disables the semi-controlled rectifier. The current limiter reduces the short circuit current.

PFC Solution with Tyco's PFC-IPM

This intelligent power module (IPM) is a complete, universally applicable PFC solution for currents up to 1 kW. The PFC-IPM is designed to reduce the input current upper waves and has the required features to realize a performance factor > 0.99. The switch is based on a boost topology, provided with a semi-controlled input rectifier.

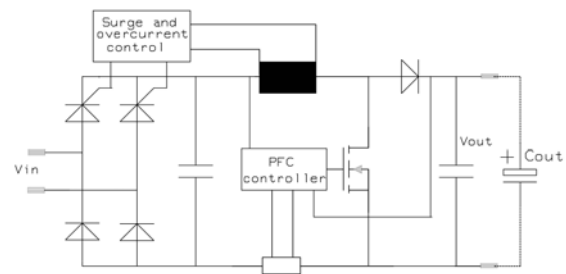

This solution has an input start switch to limit the input current and a short-circuit protection for consumers connected to the output. Another characteristic feature is the zero load capability. This means that the PFC-IPM can generate a stable DC output voltage without the necessity that a consumer must be connected to the output – a demanded must, when the application requires a highly stable output voltage.

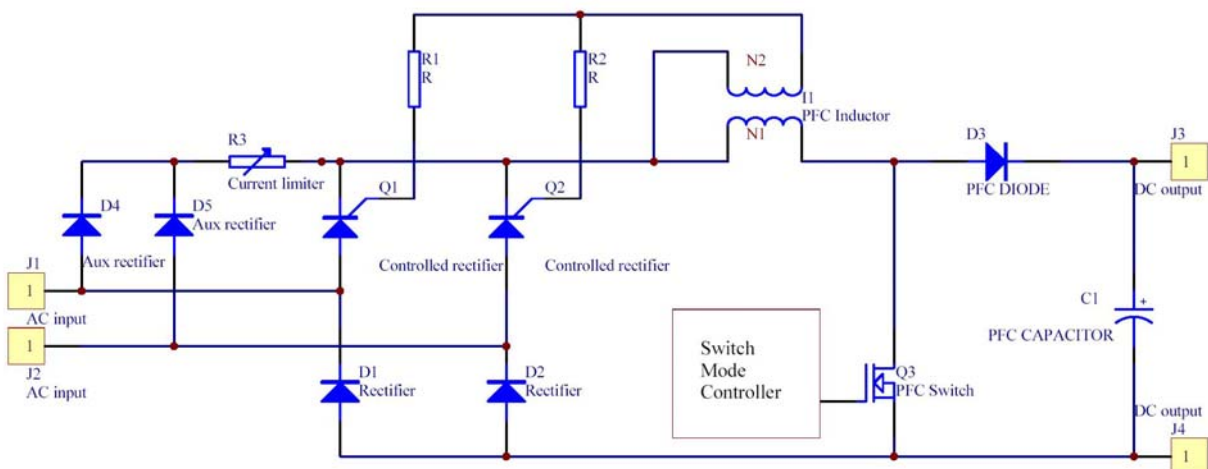

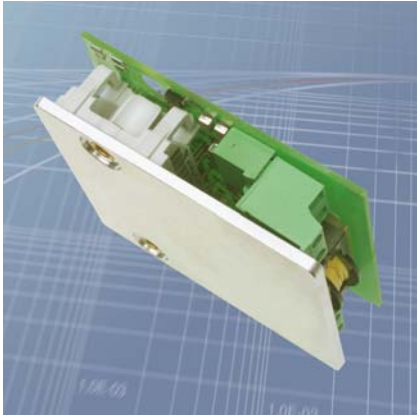

- Low-inductive current measurement with a shunt for precise control of the PFC switch
- Capacitor for low-inductive bypassing of the high frequency in the module

The Tyco PFC modules offer compact modules and the flow concept offer opportunity to get a compact and easy PCB design. All Tyco PFC solutions short the high frequency with a ceramic capacitor inside the module. The excellent EMC behavior is only possible with module solution and can never achieved with discrete components. The Clip In housing of the modules **flowPFC0** is adjustable to different PCB and makes the assembly easy and reliable. The integrated temperature sensor protects the module and the application. The UL listing of the module shortens the time to get the application certified. These advantages are a basis for an innovative and cost effective PFC solution.

The following characteristic features have been realized in this flexible, universally applicable PFC solution:

- Nominal input voltage 230 V_{AC}
- Output voltage 400 V_{DC}
- Output current (zero load) 0.. 1 kW
- Efficiency ca. 95% (including the Choke)
- Power factor > 0,99
- Starting current limiter < 12A
- Short-circuit protection for static and dynamic failures at the output

PFC Solution with Tyco's **flowPFC 0**

The following characteristic features have been realized in this flexible, power integrated concept:

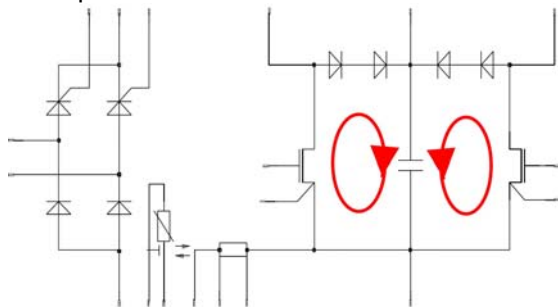

Features:

- All semiconductors integrated in one module, no additional efforts for thermal contacting required
- Integration of a temperature sensor for detection of the substrate temperature
- The proven flow concept allows a compact PCB design. Plugs with similar voltage are concentrated to voltage islands
- Symmetric design of the PFC transistor for parallel or alternating operation