

flow2

Package Dimensions

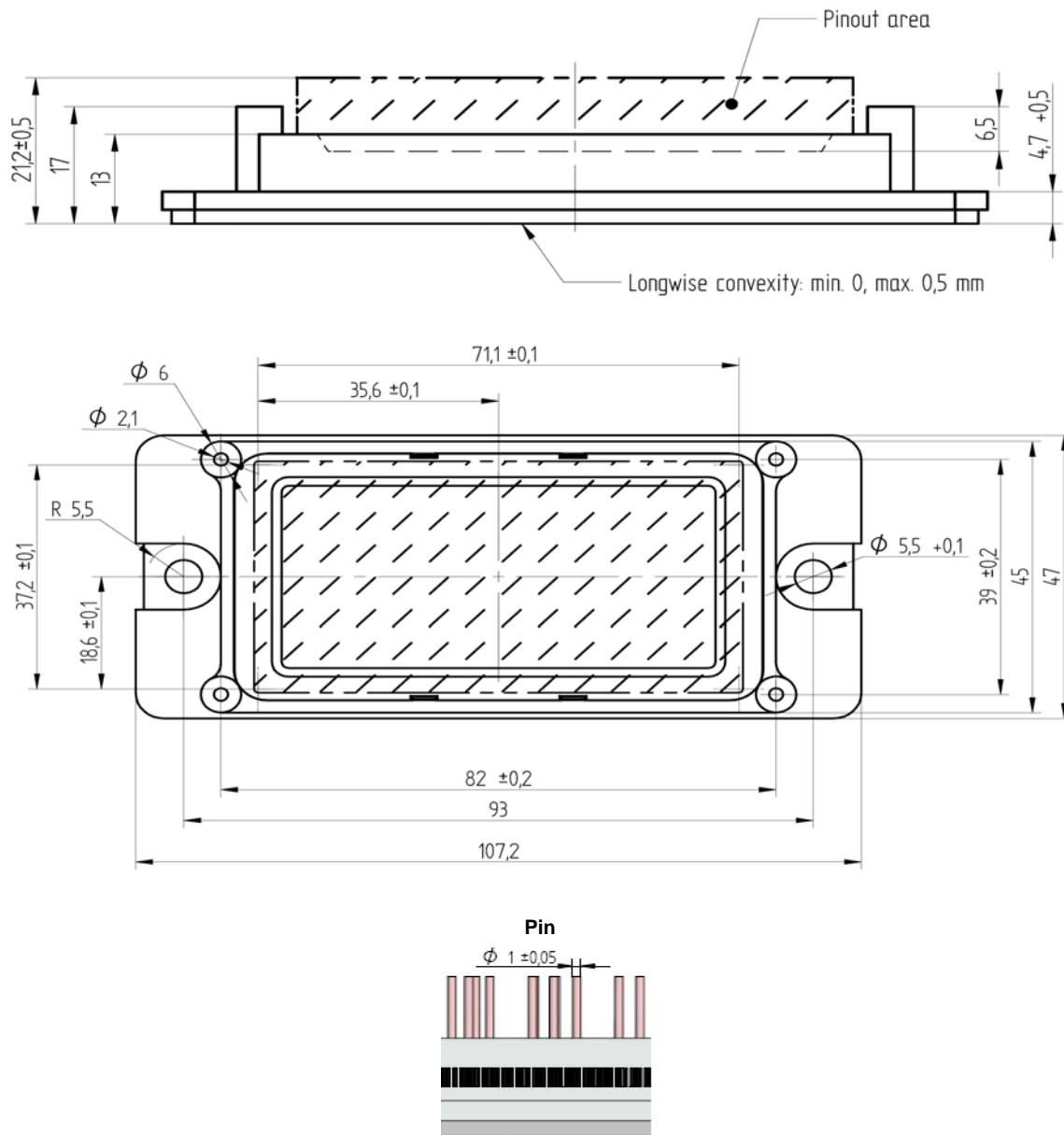

Handling Instructions

with respect to the PCB

- The module is to be screwed into the PCB using 4 screws of type BN82428 with $D = 2,5\text{mm}$ and $L = 6\text{mm}$
- After screwing, all pins are to be soldered into the PCB
- During assembly, the pins are not to be drawn or pushed more than $\pm 0.2\text{ mm}$ or loaded with a force greater than 35N
- The load of the pin is not to exceed $\pm 5\text{N}$ at a maximum substrate temperature of 100°C
- Vibration stress on the pins is to be avoided

with respect to the heatsink

- The heatsink surface must be clean and free of particles
- The flatness is to stay below 0.05 mm in 100 mm
- The surface roughness is not to exceed an R_z of 0.01 mm

with respect to the thermal paste

- The thermal conducting paste is to be applied to the entire module plate with a thickness of max. 0.05 mm
- Thicker thermal paste can potentially raise the value of R_{th}

with respect to the fastening screws to the heatsink

using a plain washer

- The screws are to be tightened using half torque first
- In the second step, all screws are to be tightened applying the full torque
- To be used is a washer with outer diameter $D = 10\text{mm}$
- To be used is an M5 screw
- To be applied is a mounting torque of $4\text{Nm} \leq M_a \leq 6\text{Nm}$
- The mounting force between PCB/Housing and baseplate is not to exceed 150N at 25°C for short periods and 50N at 100°C continuous

PRODUCT STATUS DEFINITIONS

Datasheet Status	Product Status	Definition
Target	Formative or In Design	This datasheet contains the design specifications for product development. Specifications may change in any manner without notice. The data contained is exclusively intended for technically trained staff.
Preliminary	First Production	This datasheet contains preliminary data, and supplementary data may be published at a later date. Tyco Electronics reserves the right to make changes at any time without notice in order to improve design. The data contained is exclusively intended for technically trained staff.
Final	Full Production	This datasheet contains final specifications. Tyco Electronics reserves the right to make changes at any time without notice in order to improve design. The data contained is exclusively intended for technically trained staff.

DISCLAIMER

Tyco Electronics reserves the right to make changes without further notice to any products herein to improve reliability, function or design. Tyco Electronics does not assume any liability arising out of the application or use of any product or circuit described herein; neither does it convey any license under its patent rights, nor the rights of others.

LIFE SUPPORT POLICY

Tyco Electronics products are not authorised for use as critical components in life support devices or systems without the express written approval of Tyco Electronics.

As used herein:

1. Life support devices or systems are devices or systems which, (a) are intended for surgical implant into the body, or (b) support or sustain life, or (c) whose failure to perform when properly used in accordance with instructions for use provided in labelling can be reasonably expected to result in significant injury to the user.
2. A critical component is any component of a life support device or system whose failure to perform can be reasonably expected to cause the failure of the life support device or system, or to affect its safety or effectiveness.