

Application Note No. 062

A Low Parts Count Low Noise Amplifier for GPS Applications using BGA428

Small Signal Discretes



Never stop thinking

Edition 2007-01-09

**Published by
Infineon Technologies AG
81726 München, Germany**

**© Infineon Technologies AG 2007.
All Rights Reserved.**

LEGAL DISCLAIMER

THE INFORMATION GIVEN IN THIS APPLICATION NOTE IS GIVEN AS A HINT FOR THE IMPLEMENTATION OF THE INFINEON TECHNOLOGIES COMPONENT ONLY AND SHALL NOT BE REGARDED AS ANY DESCRIPTION OR WARRANTY OF A CERTAIN FUNCTIONALITY, CONDITION OR QUALITY OF THE INFINEON TECHNOLOGIES COMPONENT. THE RECIPIENT OF THIS APPLICATION NOTE MUST VERIFY ANY FUNCTION DESCRIBED HEREIN IN THE REAL APPLICATION. INFINEON TECHNOLOGIES HEREBY DISCLAIMS ANY AND ALL WARRANTIES AND LIABILITIES OF ANY KIND (INCLUDING WITHOUT LIMITATION WARRANTIES OF NON-INFRINGEMENT OF INTELLECTUAL PROPERTY RIGHTS OF ANY THIRD PARTY) WITH RESPECT TO ANY AND ALL INFORMATION GIVEN IN THIS APPLICATION NOTE.

Information

For further information on technology, delivery terms and conditions and prices please contact your nearest Infineon Technologies Office (www.infineon.com).

Warnings

Due to technical requirements components may contain dangerous substances. For information on the types in question please contact your nearest Infineon Technologies Office.

Infineon Technologies Components may only be used in life-support devices or systems with the express written approval of Infineon Technologies, if a failure of such components can reasonably be expected to cause the failure of that life-support device or system, or to affect the safety or effectiveness of that device or system. Life support devices or systems are intended to be implanted in the human body, or to support and/or maintain and sustain and/or protect human life. If they fail, it is reasonable to assume that the health of the user or other persons may be endangered.

A Low Parts Count Low Noise Amplifier for GPS Applications using BGA428

Revision History: 2007-01-09, Rev. 2.0

Previous Version: 2000-11-20

Page	Subjects (major changes since last revision)
All	Document layout change

Trademarks

SIEGET[®] is a registered trademark of Infineon Technologies AG.

1 A Low Parts Count Low Noise Amplifier for GPS Applications using BGA428

Features

- Two-stage Low Noise Amplifier
- SIEGET[®]45-Technology with 45 GHz f_T
- Small outline SOT363-Package
- Low Noise Figure: 1.4 dB at 1.575 GHz
- 22 dB Gain at 1.575 GHz
- Requires only 2 external matching elements at 1.575 GHz

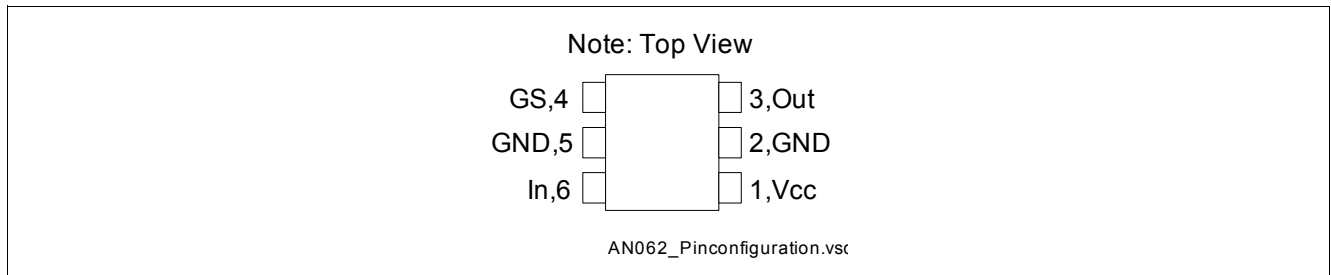
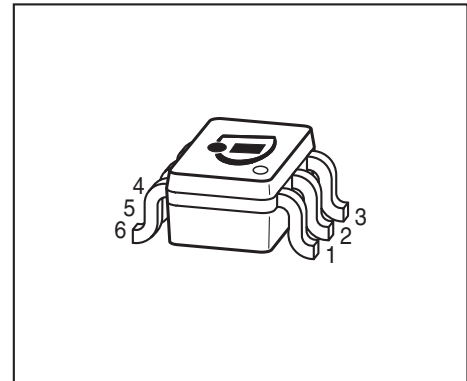

Figure 1 PIN configuration

1.1 Introduction

The Infineon BGA428 is a high performance two stage CE-CE transistor amplifier based on the BH6F-plus SIEGET[®]45-Technology.

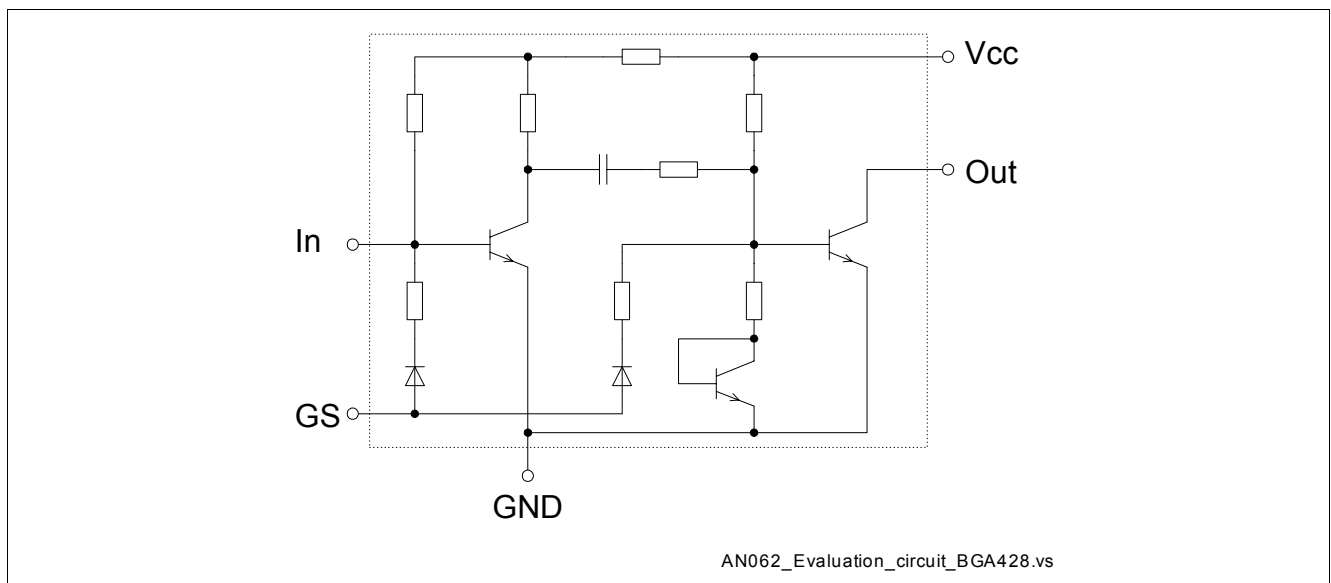

Figure 2 Equivalent Circuit of BGA428

A Low Parts Count Low Noise Amplifier for GPS Applications using BGA428

High gain and low noise figure make it an ideal solution for Low Noise Amplifiers and receiver front end stages and other applications requiring moderate linearity up to 2 GHz. Internal prematching simplifies RF design effort and enables a simple, low-parts-count RF matching solution.

The BGA428's typical supply voltage range is 2.4 to 3.3 volts. Gain may be reduced by approximately 32 dB in a single step by reducing V_{CC} to 0 V and applying 2.7 V to GS

Table 1 Performance Overview at 1.575 GHz

Parameter	Value	Unit
DC Voltage	3	V
DC Current	9.5	mA
Gain	22	dB
Noise Figure	1.4	dB
Input P_{1dB} Compression	-18.6	dBm
Input IP_3	-10	dBm
Input Return Loss	13	dB
Output Return Loss	12	dB
Reverse Isolation	34.2	dB

1.2 Description

The BGA428 is an integrated circuit consisting of two silicon bipolar transistor amplifier stages. Each transistor stage was optimized for overall device gain, linearity, noise figure and RF pre-matching. A reduced gain step is provided as well as a complete bias circuit.

The features of the BGA428 allow fast easy RF amplifier circuit designs requiring low component count and minimal printed circuit board area. DC power is provided by simply applying the proper voltage on the V_{CC} pin, although the circuit designer has the option of biasing each of the two stages separately. Internal prematching eases the external RF matching circuit can be combined with the coil that brings in DC bias.

The BGA428 is developed for use in battery powered equipment demanding high performance with low supply voltages. Typical applications for the device include low noise RF amplifiers, IF amplifiers and gain and buffer stages up to 2 GHz. The BGA428 is an excellent choice for use in cellular and cordless telephones and other commercial wireless equipment.

1.3 Design overview

This application note describes a low noise amplifier for 1.575 GHz. The schematic diagram is shown in [Figure 3](#). Amplifier design using BGA428 is no big effort.

Output matching is done by using a high-pass shunt L-series C (L1 and C6) matching circuit, as shown in [Figure 3](#). In this configuration the inductor can be used for both the RF output match and the DC biasing of the second stage. The series C element serves both an RF matching and a DC blocking function.

There is no need for an input matching circuit. The BGA428's internal prematching offers a good trade-off between high gain and low noise figure with sufficient low return loss for most applications. The BGA428's input return loss values in the frequency band of interest are typically slightly better 10 dB. Capacitor C1 is only required if the amplifier is cascaded with stages that do not present a DC open circuit to the BGA428.

No stabilization measures have to be taken. Due its internal prematching, the BGA428 offers a high degree of stability sufficient for most applications.

In this application the gain step feature was not implemented to keep the parts count at minimum.

The following pages show the circuit diagram, bill of materials, PCB layout and measured data.

A Low Parts Count Low Noise Amplifier for GPS Applications using BGA428

All parameters were measured at 25 °C and include the losses of the SMA connectors and microstrip lines on the PCB boards.

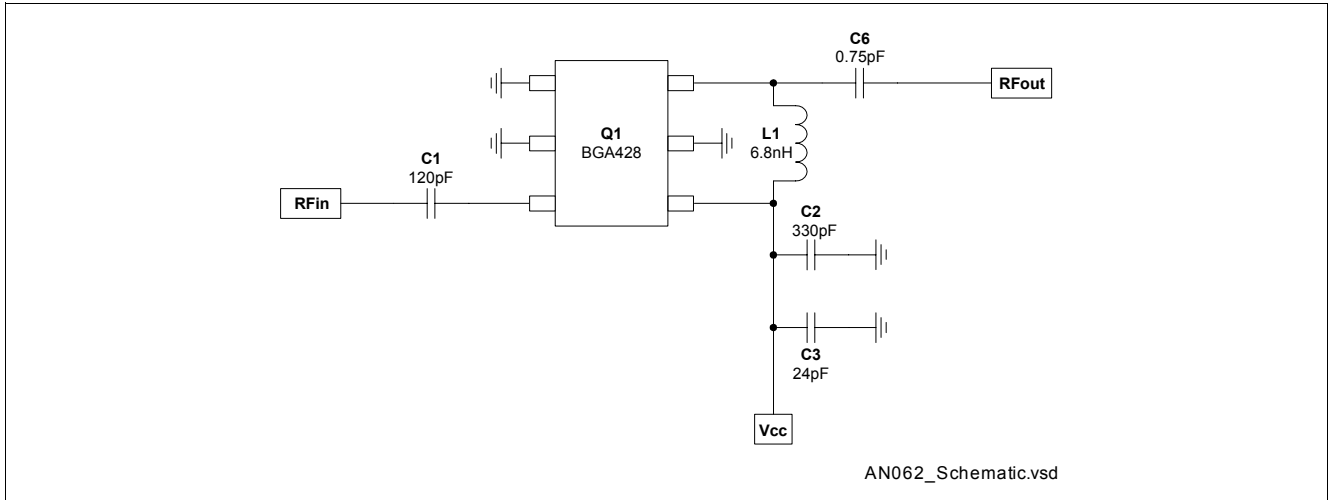

Figure 3 Schematic Diagram

Table 2 Bill of Material

Component	Value	Unit	Size	Manufacturer	Comment
C1	120	pF	0402	Various	DC block
C2	330	pF	0402	Various	RF bypass
C3	24	pF	0402	Various	RF bypass
C4	0.75	pF	0402	Various	Output match, DC block
L1	6.8	nH	0402	Toko LL 1005-FH	Output match, DC feed for 2 nd stage
Q1			SOT363	Infineon Technologies	

A Low Parts Count Low Noise Amplifier for GPS Applications using BGA428

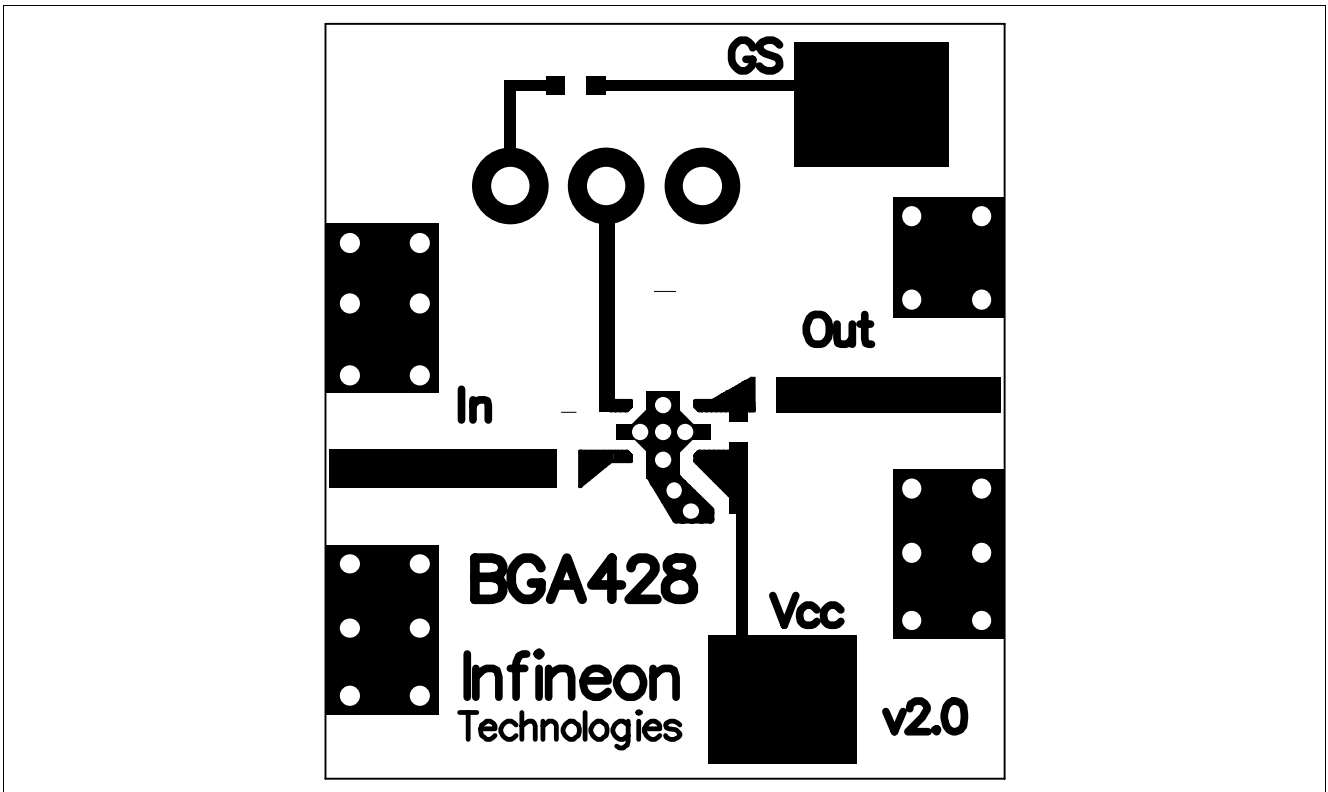

Figure 4 Application Board

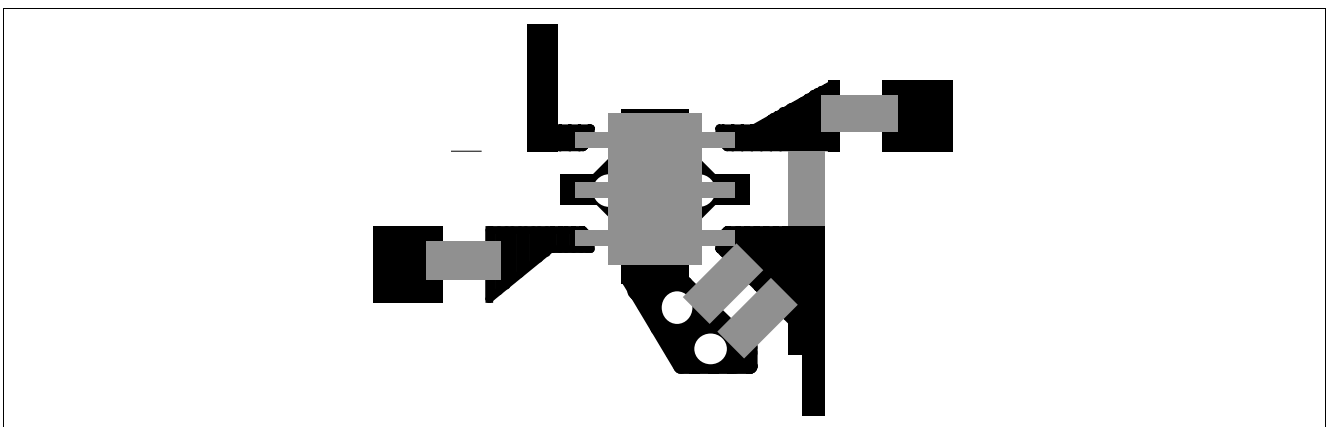

Figure 5 Component Placement

2 Measurement results

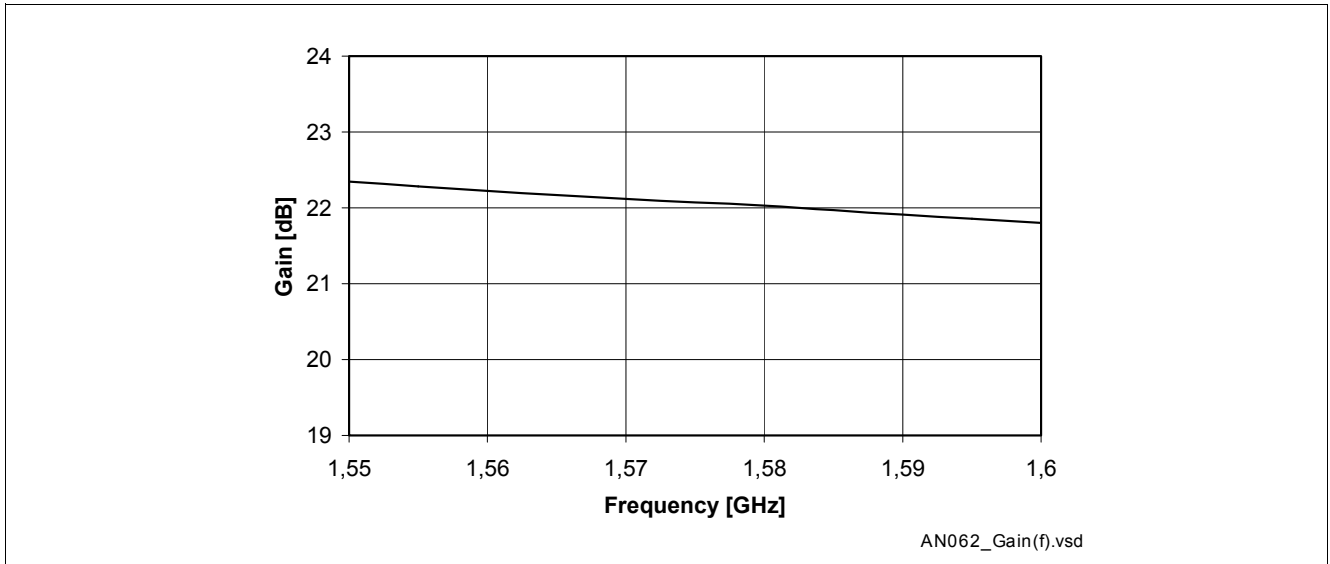

Figure 6 Measured Gain

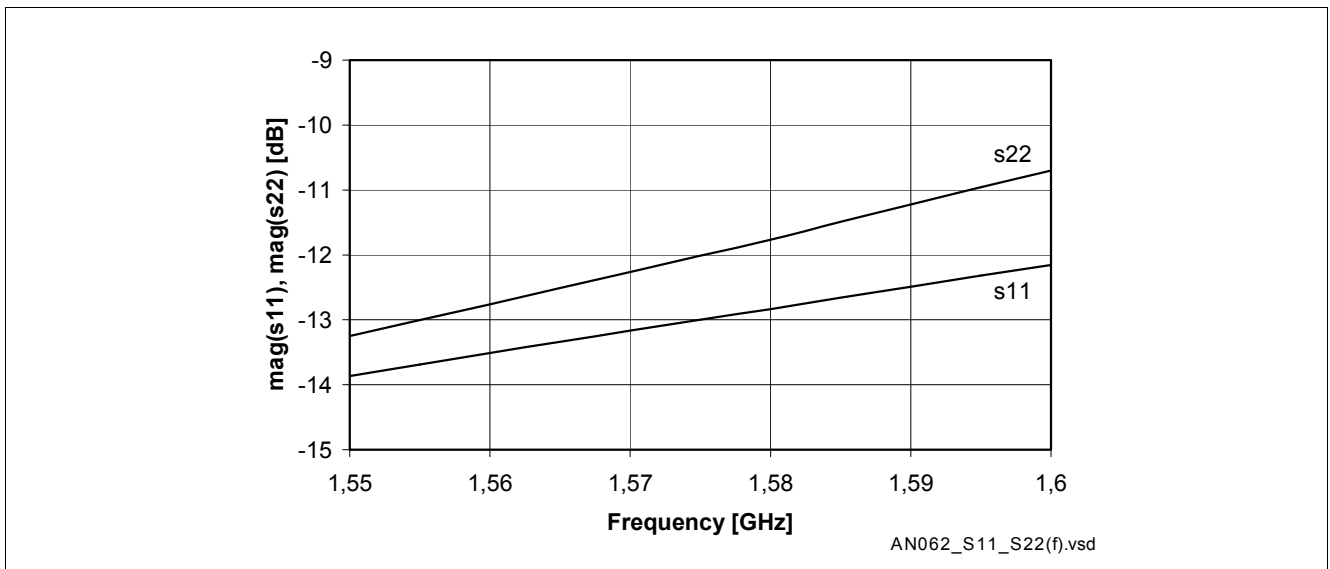

Figure 7 Measured Input and Output Return Loss

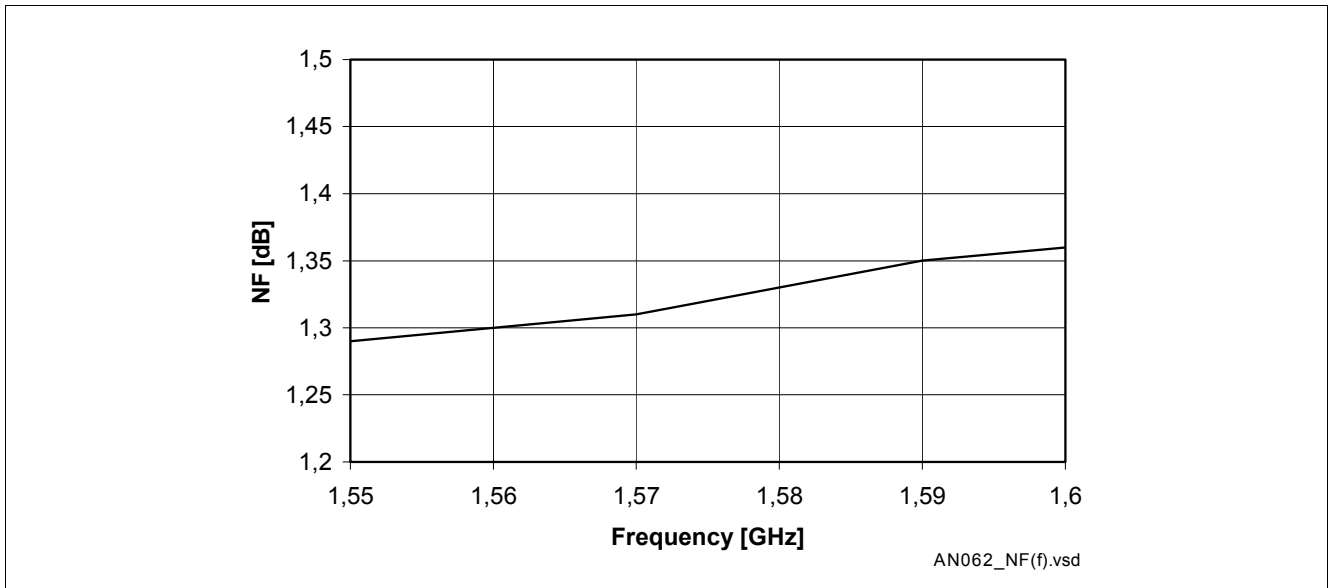

Figure 8 Measured Noise Figure

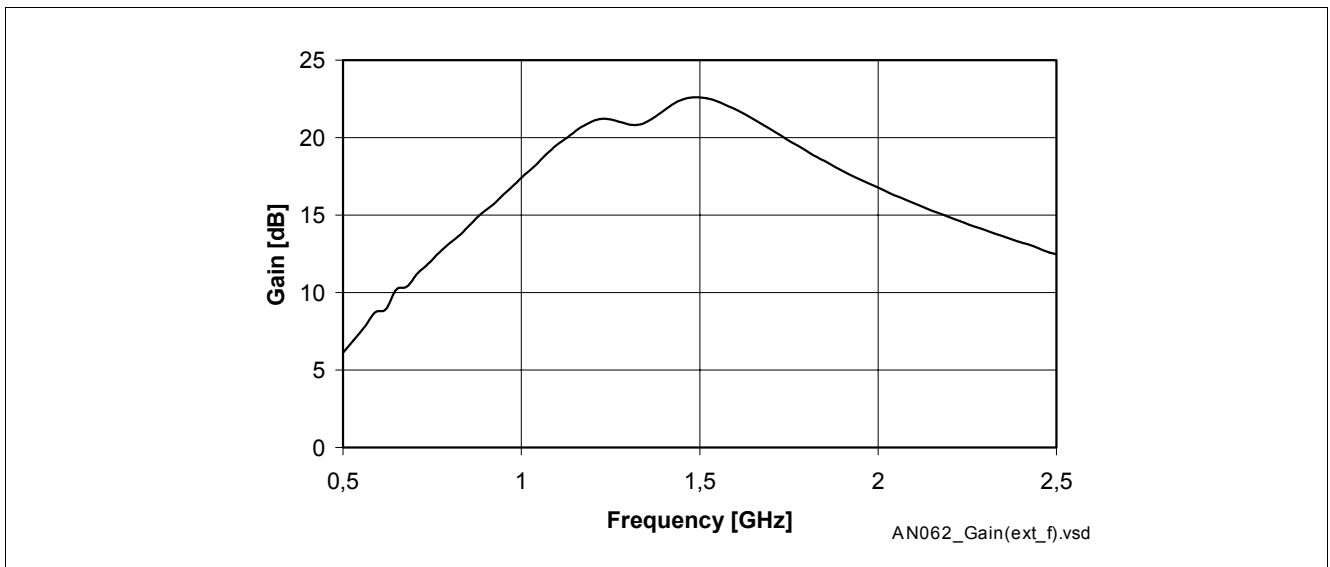

Figure 9 Measured Gain for Extended Frequency

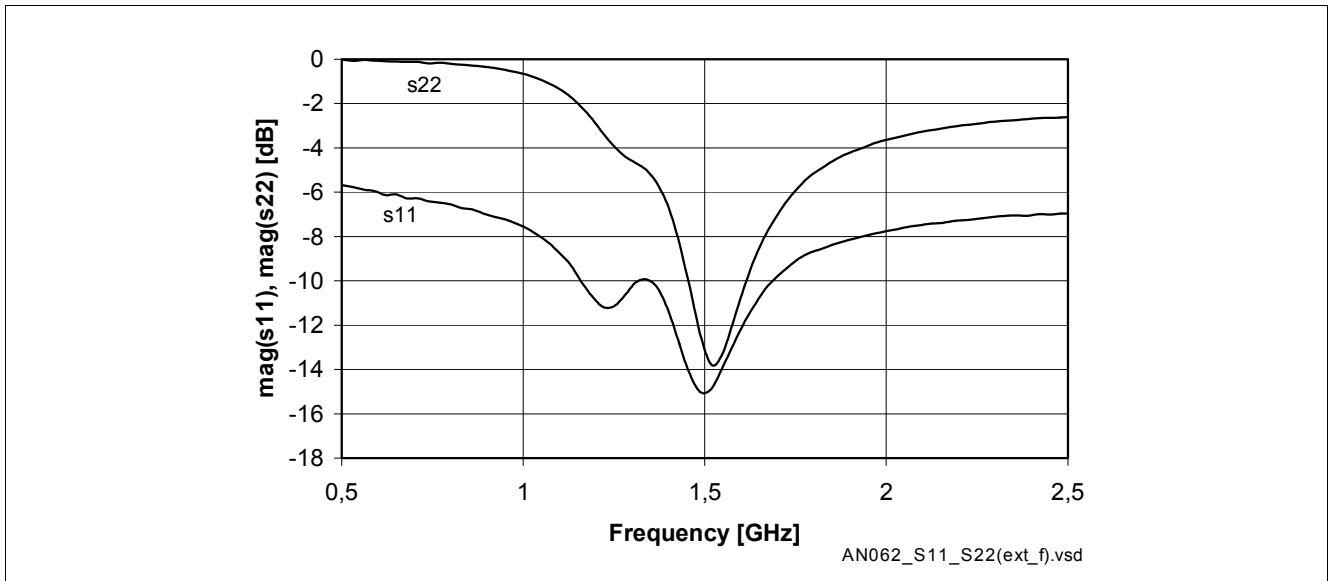

Figure 10 Measured Input and Output Return Loss for Extended Frequency

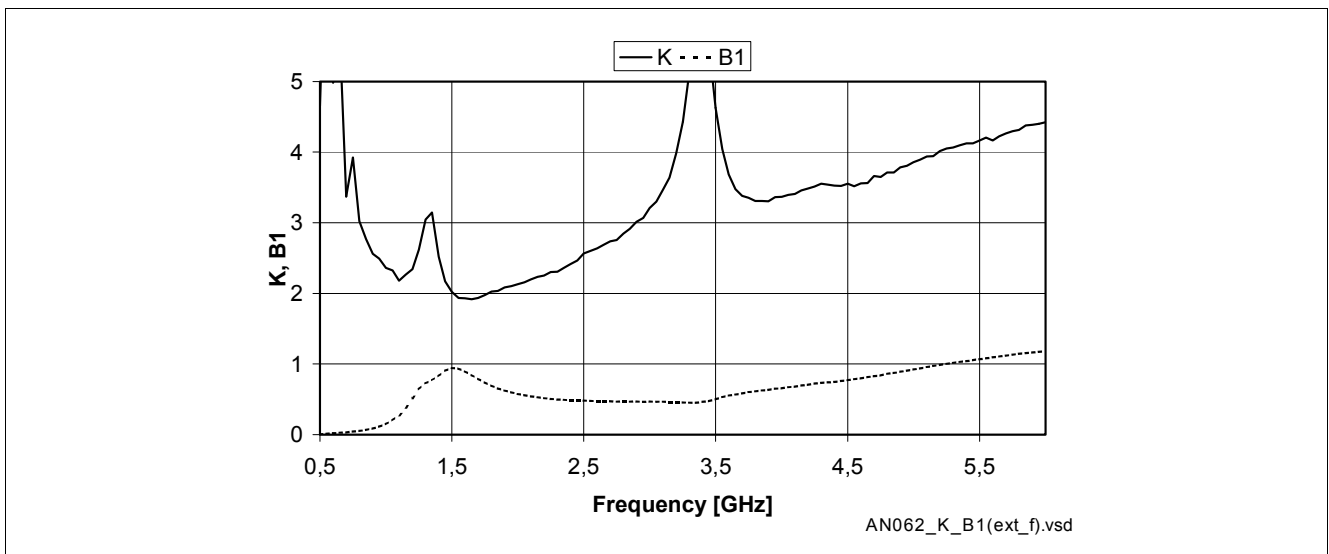

Figure 11 Measured Stability Factor K and Stability Measured B1

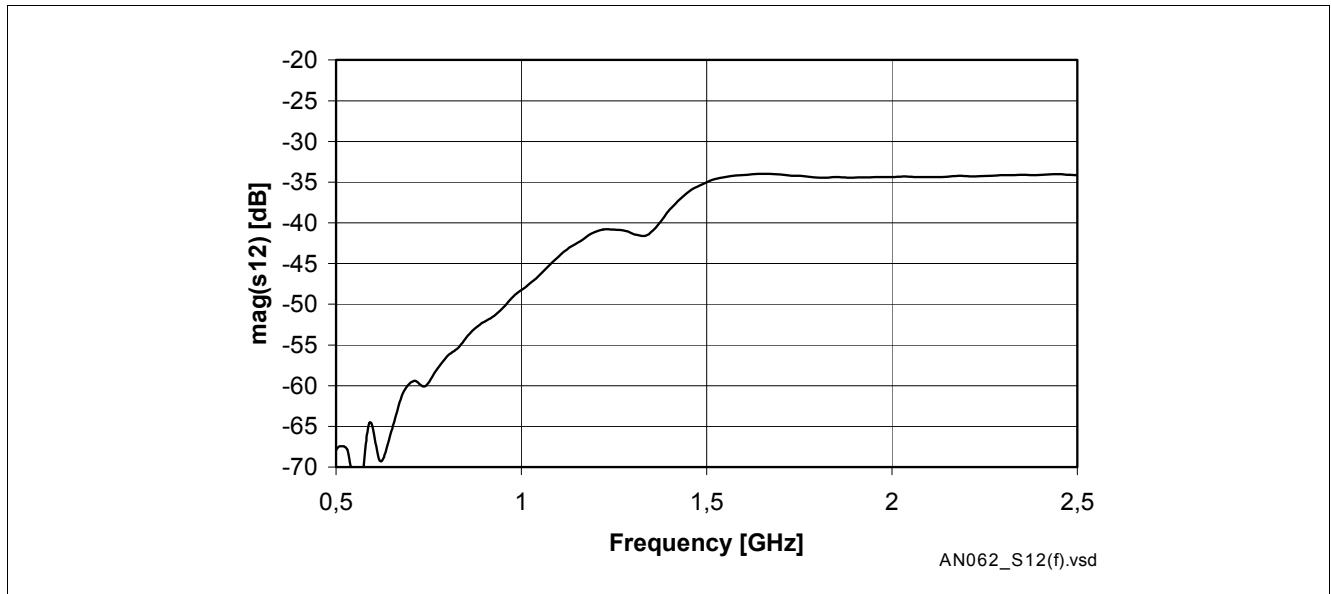

Figure 12 Measured Reverse Isolation