

# Pressing Home the Advantages

## *Press-Fit pin for solder-less assembly*

*Solder pins have been the interface of choice for power modules for many years. The new press-fit pin developed by Vincotech takes the assembly properties of Vincotech power modules a step further: the solder-less assembly of the modules, equally easy on both sides of the PCB, leads to higher reliability and design flexibility and drastically reduces production costs.*

*By Peter Sontheimer, Vincotech*

### **The target: faster and easier assembly**

Common inverter construction today features large Through The Hole (TTH) components along with smaller SMD devices on one side of the PCB, with the power module mounted on the other side and connected to the heat sink (see fig 1). Only in exceptional cases, where space allows and where special heat sink shapes are possible, the power module is mounted on the same side as all other components. This means that wave-soldering of the power module is not possible. The solution most usually adopted in these cases is either a manual solder process, which immediately raises questions regarding reliability and production efficiency, or selective robot soldering, entailing the same production efficiency issues as well as higher costs.

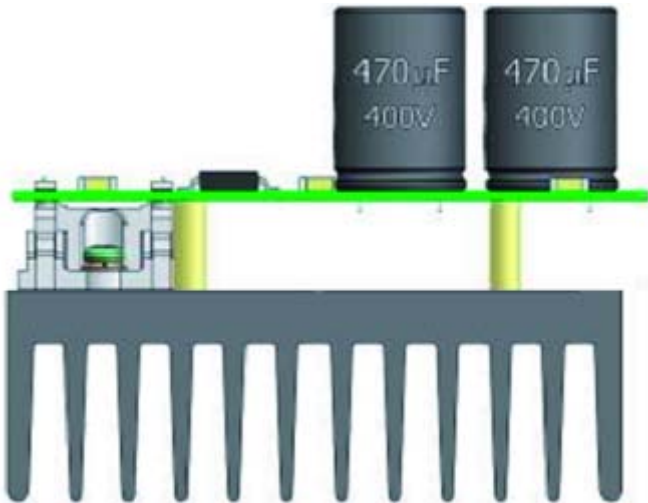

Figure 1: large TTH and SMD components on one side with the solder pin power module on the other: selective soldering process for the power module is necessary

The aim was therefore to develop an interconnect technology that would eliminate the need for soldering of the power module, whilst maintaining the reliability standards and electrical capabilities of the solder pin. This would make the assembly process of the modules easier, faster, and, in effect, more cost-effective. Furthermore, the target was, to realize the exact same layouts as those of the solder modules. The Vincotech press-fit pin is the perfect answer.

### **Press-fit pin**

The Vincotech press-fit pin features a tapered pin-head and a round press fit area (see fig 2). Well-established in the Automotive Industry,

the pin design is such that it requires high push-out forces. Compliant to DIN and IEC standards, the elastic properties of the press fit area ensure that the PCB through-hole metallization suffers no damage when inserting or extracting the module. This means that the module can be replaced and the same PCB re-used at no risk to the reliability or the electrical properties of the system. Also, several plating and material combinations were tested and the optimum solution chosen.

The press-fit pin, however, is not based only on brand new concepts; it combines the innovative press-fit zone with all long-serving and proven features of the standard Vincotech solder pin, such as the pull-force relaxation mechanism (stress relief) for high mechanical robustness (see fig 2).

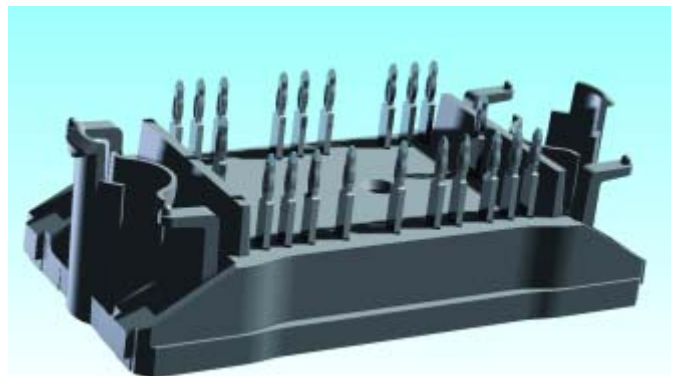

Figure 2a and b: The Vincotech press-fit pin: tapered pin head and round press-fit area in the press-fit zone; stress relief mechanism in base

### Electrical characteristics and Reliability

Capable of 30A DC current at heat sink temperature of 80°C, the press-fit pin has the exact same current capabilities as the solder pin. This is due to the pin cooling directly because of the solder assembly to the substrate and to the very large contact area between the press-fit zone and PCB hole metallization (see fig 3). Combined with the optimized design of the press-fit zone, this in turn leads to an ever higher reliability than for the solder pin [1].

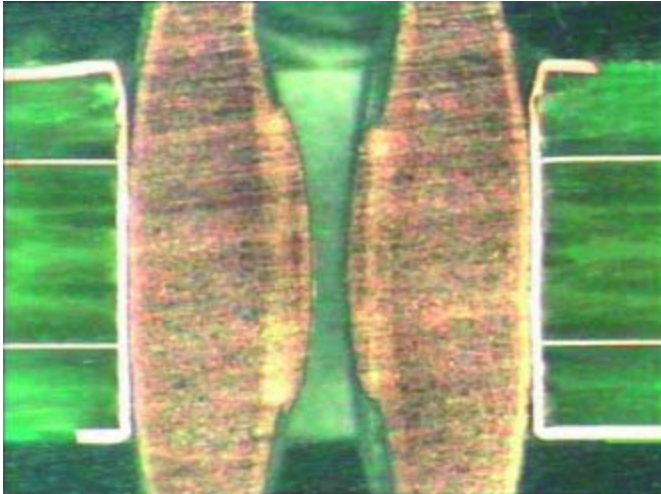

Figure 3: Large contact area of Vincotech press-fit pin to PCB hole (Sn surface finish)

### Press-fit pin assembly

As the name implies, the cold welding connection to the PCB is achieved by pressing the pin into the PCB. The result is a gas-tight and reliable connection between pin and PCB. The elimination of the solder process leads to shorter production costs due to the lack of specialized robot equipment and the lower throughput time; assembly of the module is achieved in a few seconds as opposed to minutes. A further advantage is the elimination of soldering flux leftovers, which would require an additional cleaning step in the production line.

### The press-in tool

Modules featuring the press-fit pin are mounted onto the PCB with the aid of a press-in tool; an example of such a tool is shown in fig 4. The module is kept in place by two position pins. The PCB is then pressed onto the pins with an equally distributed and well-controlled press-in force of up to 110N, depending on the PCB and hole parameters. The simple handling of the press-in tool ensures the smooth,

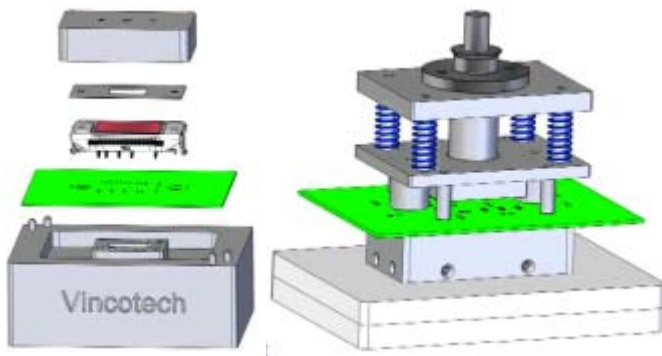

Figure 4a and 4b: Example of a press-in tool: the module is held in place by the position pins; the PCB is pressed onto the module by the upper arm with an even and controlled force (path and force sensors not shown in this illustration)

reliable and fast assembly of the modules, with path and force sensors controlling every step (not shown in fig 3). The only restriction on the PCB layout is a clearance of 4mm from the middle of the PCB hole to the next SMD component (see fig 5).

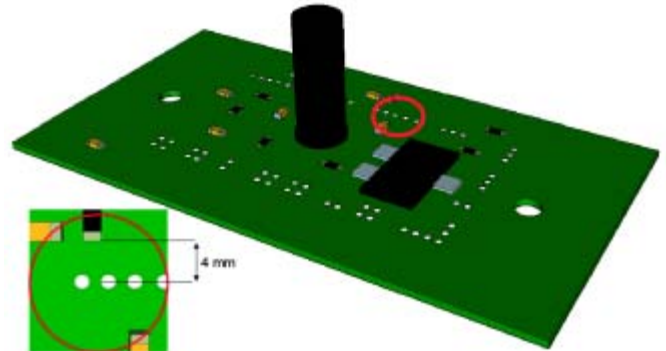

Figure 5: a clearance of 4mm between the PCB hole centre and the closest SMD component is required to allow for the use of the press-in tool

### The PCB

The Vincotech press-fit pin can be used with both Halogen-free and Lead-free PCBs of any thickness. Although the pin supports both HA(S)L and I-Sn surface finishes, I-Sn is recommended due to its higher thickness accuracy, leading to a stable press-in process. Required is a final hole diameter of 1,45mm with tolerances of -60um and +90um, as stated in the DIN standard [2].

### The Vincotech modules featuring press-fit technology

The Vincotech press-fit pin was developed as a one-to-one replacement of the solder pin. This means that all Vincotech power modules, be it standard or custom, can easily be equipped with the press-fit pin and do not require a PCB layout change by the customer. A further important feature is that the same press-fit area is used for all power ranges: the three versions of the pin differ only in length in order to accommodate the different housing heights.

### Conclusion

The Vincotech press-fit pin offers the perfect solution for solder-less assembly. In this day and age, when cost saving very often leads to compromises in quality, Vincotech's new press-fit technology goes against the trend: highly reliable and electrically equal to the solder pin, this new interconnect technology reduces assembly time and cost whilst increasing reliability. Added benefits are design flexibility, free choice of PCB thickness, and easy PCB repair and re-use.

[www.vincotech.com](http://www.vincotech.com)

### [1] SIEMENS NORM SN 29500-5

„Ausfallraten Bauelemente Teil 5: Erwartungswerte von elektrischen Verbindungsstellen, elektrischen Steckverbindern und Steckfassungen“ (2004)

### [2] DIN EN 60352-5: 2001 (IEC 60352-5:2001),

„Solderless connections. Press-in connections. General requirements, test methods and practical guidance“ (2001)